



Te Marautanga o Aotearoa

# Whanaketanga Pāngarau

He Aratohu  
mā te Pouako



## He Mihi

Tēnei te mihi nā Te Tāhuhu o te Mātauranga me Te Pou Taki Kōrero ki ngā kaituhi, a He Kupenga Hao i te Reo, mō te rauemi mīharo nei mā ngā pouako, ngā whānau, ngā ākongā hoki o te motu. Kia ora rawa atu ki a koutou e whakapau kaha nei ki te whakaoti i te rauemi nei.

Nā Phillip Paea ngā pikitia kei ngā whārangi 7 (te tēpu me te tūru), 11 (ngā kōura), 12 (ngā kōura), 15 (te tūru me ngā poraka), 16, 25, 26, 28, 30, 32, 33 (ngā tāngata kei te taputapu hākinakina), 35, 41 (ngā tīkiti), 43, 50 (te pūrere takahurihuri), 58, 64 (te taputapu ine-mahana), 65 (ngā whakamātautau), 68 (te pouaka), 69, 86, 87, 91, me 96 mana pupuri © Te Karauna 2010. Nā Polina Outkina ngā pikitia kei ngā whārangi 7 (ngā pōro me te ine-taumaha), 8–10, 11 (ngā taruke), 12 (ngā āporo kei roto i te kumete), 14 (te tangata e whetoko ana), 17, 18–20, 24 (te kōtiro, te pākete, me te motukā), 27, 29, 31, 33 (te tēpa-ine, te pukapuka, me te rīpene), 35 (i pūtaka mai tēnei pikitia i Google Maps, nā Polina i tuhi anō mō tēnei pukapuka, mana pupuri i te mea taketake © Google Maps), 37, 38, 40, 41 (ngā pēke moni me te pouaka), 46, 50 (ngā māpere kei roto i te pouaka), 51–53, 54, 63, 64 (te pēke moni), 65 (ngā pēke āporo), 68 (te pēke wairākau), 70 (te tangata e oma ana me tērā e ine ana me te wāti tū), 73–77, 79, me 87–90 mana pupuri © Te Karauna 2010. Nā Liz Tui-Morris ngā pikitia o ngā oko kei whārangi 5 mana pupuri © Te Karauna 2010. Nā Shutterstock ngā pikitia kei ngā whārangi 5 (ngā rōpere), 6 (ngā kāri), me 22 (ngā kāri) mana pupuri © Shutterstock. Nā Chamblett Design ngā pikitia o ngā ringa me te kōtiro e whakaatu ana i tana mārō kei whārangi 14 mana pupuri © Te Karauna 2006. Nā Geo Atlas te pikitia kei whārangi 71 mana pupuri © Graphi-Ogre 2001. Nā Leilani Isara ngā pikitia kei ngā whārangi 42, 45, 56, 57 (ngā poraka), 70 (ngā poraka), 92, me 94 mana pupuri © Te Karauna 2010. Nā te kaituhi me ngā kaihoahoa ērā atu hoahoa me ērā atu kauwhata katoa mana pupuri © Te Karauna 2010.

Nā Adrian Heke te whakaahua o te uhi mana pupuri © Te Karauna 2010. Nā Shutterstock te whakaahua o te tama kei whārangi 24, ngā penerākau me ngā pene kei whārangi 44, me te kete kei te whārangi 33 mana pupuri Shutterstock.

Ētita: Hēni Jacob

Kāhui kaihoahoa: Phillip Paea, Liz Tui-Morris rātou ko Leilani Isara

I whakaputaina tēnei pukapuka i te tau 2010 mō Te Tāhuhu o te Mātauranga e Te Pou Taki Kōrero Whāiti, Pouaka 3293, Te Whanganui-a-Tara 6140, Aotearoa.  
[www.learningmedia.co.nz](http://www.learningmedia.co.nz)

Mana pupuri © Te Karauna 2010

Ngā tono ki te kaiwhakaputa i te pukapuka.

Ki te hiahia koe ki ētahi atu kape o tēnei rauemi, whakapā mai ki:

Te Ratonga Kiritaki a Te Tāhuhu o te Mātauranga

Waea koreutu 0800 660 662

Waea whakaahua koreutu 0800 660 663

Īmēra: [orders@thechair.minedu.govt.nz](mailto:orders@thechair.minedu.govt.nz)

Tono mai rānei mā te Ipurangi [www.thechair.minedu.govt.nz](http://www.thechair.minedu.govt.nz)

Me mātua homai te nama take 33643

ISBN 978 0 7903 3643 5

Nama take 33643

Whanaketanga Pāngarau (pepa whewhera): nama take 11540

Whanaketanga Pāngarau (tūtohi pakitara): nama take 11539

Whanaketanga Reo: Kōrero, Pānui, Tuhihi: He Aratohu mā te Pouako nama take 33642

Whanaketanga Reo: Kōrero, Pānui, Tuhihi (pepa whewhera): nama take 11541

Whanaketanga Reo: Kōrero, Pānui, Tuhihi (tūtohi pakitara): nama take 11542



Te Marautanga o Aotearoa

# Whanaketanga Pāngarau

He Aratohu  
mā te Pouako



## 4 He Kupu Whakamārama

## 5 Whanaketanga 1a

- 5 Te Tau
- 6 Te Tauira me te Pānga
- 7 Te Ine me te Hanga
- 9 Te Wāhi, te Ahunga, me te Panoni
- 10 Te Tauanga

## 11 Whanaketanga 1e

- 11 Te Tau
- 13 Te Tauira me te Pānga
- 14 Te Ine me te Hanga
- 16 Te Wāhi, te Ahunga, me te Panoni
- 17 Te Tauanga
- 18 Te Tūponotanga

## 19 Whanaketanga 2a

- 19 Te Tau
- 21 Te Tauira me te Pānga
- 23 Te Ine me te Hanga
- 25 Te Wāhi, te Ahunga, me te Panoni
- 27 Te Tauanga
- 28 Te Tūponotanga

## 29 Whanaketanga 2e

- 29 Te Tau
- 31 Te Tauira me te Pānga
- 32 Te Ine me te Hanga
- 34 Te Wāhi, te Ahunga, me te Panoni
- 36 Te Tauanga
- 38 Te Tūponotanga

## 40 Whanaketanga 3a

- 40 Te Tau
- 43 Te Tauira me te Pānga
- 45 Te Ine me te Hanga
- 47 Te Wāhi, te Ahunga, me te Panoni
- 49 Te Tauanga
- 50 Te Tūponotanga

## 51 Whanaketanga 3e

- 51 Te Tau
- 55 Te Tauira me te Pānga
- 56 Te Ine me te Hanga
- 58 Te Wāhi, te Ahunga, me te Panoni
- 60 Te Tauanga
- 62 Te Tūponotanga

## 63 Whanaketanga 4a

- 63 Te Tau
- 66 Te Tauira me te Pānga
- 68 Te Ine me te Hanga
- 71 Te Wāhi, te Ahunga, me te Panoni
- 73 Te Tauanga
- 74 Te Tūponotanga

## 75 Whanaketanga 4e

- 75 Te Tau
- 78 Te Tauira me te Pānga
- 80 Te Ine me te Hanga
- 82 Te Wāhi, te Ahunga, me te Panoni
- 84 Te Tauanga
- 86 Te Tūponotanga

## 87 Whanaketanga 5a

- 87 Te Tau
- 90 Te Tauira me te Pānga
- 91 Te Ine me te Hanga
- 93 Te Wāhi, te Ahunga, me te Panoni
- 95 Te Tauanga
- 96 Te Tūponotanga

## 97 Te Takenga mai o Ētahi o ngā Ngohe

## 98 He Kupu Taka

# NGĀ WHANAKETANGA: PĀNGARAU

## HE KUPU WHAKAMĀRAMA

He mea pūtake mai ngā whanaketanga i ngā whāinga paetae o te pāngarau i roto i *Te Marautanga o Aotearoa*<sup>1</sup>. E iwa ngā whanaketanga pāngarau e hāngai ana ki ngā taumata 1 ki te 5 o te marautanga, ā, kei te hono hoki ki ngā kaupae o Te Mahere Tau.

Koia nei ngā hononga:

Marautanga	Whanaketanga	Kaupae
Taumata 1	1a	0–2
Taumata 1	1e	3–4
Taumata 2	2a	5
Taumata 2	2e	5
Taumata 3	3a	6
Taumata 3	3e	6
Taumata 4	4a	7
Taumata 4	4e	7–8
Taumata 5	5a	8

Ko tā ngā whanaketanga, he āta tohu i te tipu o te mātauranga me ngā pūkenga o te ākongā, hei āwhina i te pouako ki te whakamahere i ngā akoranga, ki te aromatawai hoki i te ākongā. Kei roto i te pukapuka nei ētahi taurira mahi hei tohu i ngā taumata e hāngai ana ki tēnā whanaketanga ki tēnā.

E arotahi ana ngā whanaketanga ki ngā ariā matua o te pāngarau, me te tūhonohono o ngā ariā. Ko te mea nui ko tā te ākongā tūhonohono i tana mātauranga me tana whakamahi i āna pūkenga ki te whakaoti rapanga. Koia rā te take e noho mai ana te whakaoti rapanga hei tūāpapa mō ngā whanaketanga.

I roto i te mahi whakaoti rapanga, ka whakamahi, ka tūhonohono te ākongā i tana mātauranga, āna pūkenga, me āna rautaki, ka āta whiriwhiri i te rautaki e tino whaihua ana, ka kimi pānga, ka matapae, ka kimi taurira, ka whakatau tata, ā, ka tātai i te otinga tōtika.

Kua wehea ia whanaketanga ki ngā tino wāhanga e ono nei o te pāngarau, e noho mai ana ki raro i ngā whenu e toru o te marautanga pāngarau:

Ngā whenu	Ngā tino wāhanga o te pāngarau
Te Tau me te Taurangi	Te Tau (Te Mātauranga Tau me ngā Rautaki Tau) Te Taurira me te Pānga
Te Ine me te Āhuahanga	Te Ine me te Hanga Te Wāhi, te Ahunga, me te Panoni
Te Tauanga	Te Tauanga Te Tūponotanga

Ehara i te mea kia ōrite te wā ako o tēnā whenu o tēnā. Ko te Tau te tūāpapa o te pāngarau, nō reira e tika ana kia nui ake te aro ki tēnei whenu i ngā tau tīmatanga o te kura, kātahi ka piki haere te aro ki whenu kē. Kei te pouako, kei te kura tonu te whiriwhiri i tēnei āhuatanga, engari ka tino puta hoki te Tau i roto i ērā atu o ngā whenu, pērā i te Ine me te Tauanga. Ko te aronga matua kei ngā taumata teitei, ko te Taurangi me ōna hononga ki ngā whenu katoa o te pāngarau.

Kei te taha matau o ngā whanaketanga te whakapākehātanga o ētahi o ngā kupu pāngarau hei āwhina noa iho i te rere o te pānui. Ki te kore e mārama te tikanga o aua kupu pāngarau, me tiro tiro te papakupu *Te Reo Pāngarau*<sup>2</sup>, kei reira ngā whakamāramatanga.

Ko te reo matatini o te pāngarau tētahi āhuatanga matua e kitea mai ana i roto i ngā whanaketanga. He mea nui tā te ākongā whakamahi i ngā kupu, ngā tohu, me ngā whakaahuahanga motuhake o te pāngarau, e mārama ai ia ki ngā kaupapa e akohia ana. Ina pakeke haere te ākongā, ka whānui haere, ka hōhono haere tōna reo matatini o te pāngarau. He mea nui kia whāngaihia ki ngā kupu tika i ngā taumata pāpaku, e pai ai tana eke i ngā taumata teitei ā tōna wā.

I te wā e whakaoti rapanga ana te ākongā, e whakamārama ana i tana otinga, e pai ana te whakamahi rauemi, taputapu hoki, me te tuhi pikitia, hoahoa rānei. Ko te mea nui kia āta kitea te arorau me te auaha o ōna whakaaro. Mēnā kāore anō te ākongā kia eke i te taumata e taea e ia ngā rapanga te pānui, mā te pouako anō e pānui, pēnei i Te Uiu Aromatawai o Te Poutama Tau.

<sup>1</sup> Te Tāhuhu o te Mātauranga (2008). *Te Marautanga o Aotearoa*. Te Whanganui-a-Tara: Te Pou Taki Kōrero. Whārangi 40

<sup>2</sup> *Te Reo Pāngarau*. [2010]. Papaioea: He Kupenga Hao i te Reo.

# WHANAKETANGA 1a

## Te Tau: Te Mātauranga Tau me ngā Rautaki Tau

(TPT) Kaupae 0–2

Ngā Whāinga		
Ka whakaoti rapanga te ākonga, ka whakamārama otinga, e whai wāhi mai ana:	He tauira ēnei o ngā āhuetanga me mātua mōhio te ākonga e tutuki ai tana whakaoti rapanga:	
<ul style="list-style-type: none"> <li>ngā rautaki tatau pānga-tahi<sup>1</sup> hei whakaoti paheko tau.</li> </ul>	<ul style="list-style-type: none"> <li>ngā tauoti mai i te 0 ki te 20, arā, ko ngā tohutau, ngā kupu tau, me te rahi o ngā tau</li> <li>te whakaahuahanga<sup>2</sup> me te raupapa o ngā tau</li> <li>ngā tau rearua ki te 10 me ngā haurua e whai pānga ana</li> <li>te mātauranga uara tū<sup>3</sup> e hāngai ana, pēnei i ngā tauhono takirua<sup>4</sup> o roto i te 5 me te 10, me ngā wāwāhitanga uara tū<sup>5</sup>.</li> </ul>	<p><sup>1</sup>one to one counting strategies</p> <p><sup>2</sup>representation</p> <p><sup>3</sup>place value</p> <p><sup>4</sup>additive number pairs</p> <p><sup>5</sup>place value partitioning</p>

## Te Reo Matatini o te Pāngarau

Hei tauira kupu		
<ul style="list-style-type: none"> <li>ngā kupu tau, 0 ki te 20</li> <li>whakamuri</li> <li>haurua</li> </ul>	<ul style="list-style-type: none"> <li>tatau/kaute</li> <li>tauhono</li> </ul>	<ul style="list-style-type: none"> <li>whakamua</li> <li>rearua</li> </ul>
Hei tauira tohu		
<ul style="list-style-type: none"> <li>ngā tohutau</li> <li>=</li> </ul>	<ul style="list-style-type: none"> <li>+</li> </ul>	<ul style="list-style-type: none"> <li>-</li> </ul>
Hei tauira whakaahuahanga		
<ul style="list-style-type: none"> <li>he rārangi tau</li> </ul>	<ul style="list-style-type: none"> <li>he anga tekau</li> </ul>	<ul style="list-style-type: none"> <li>ngā matimati</li> </ul>

## He Tauira Rapanga

### Te Tau 1a

#### Rapanga 1

E 5 ngā rōpere a Maioha, e 3 ā Tama. E hia katoa ā rāua rōpere?



Kia tika te otinga (8), mā te tatau i te katoa o ngā rōpere mai i te 1 ki te 8. Ka tatau i ngā pikitia, ka tatau rānei i ētahi taonga hei tohu i ngā rōpere, pēnei i te matimati, i te porotiti rānei.

### Te Tau 1a

#### Rapanga 2

E 9 ngā rōpere, e 6 ka kainga e Tama. E hia ngā rōpere e toe ana?



Kia tika te otinga (3), mā tētahi rautaki tatau.

### Te Tau 1a

#### Rapanga 3

E 4 ngā rōpere kei ia kumete. E hia katoa ngā rōpere?



Kia tika te otinga (12), mā te tatau i te katoa o ngā rōpere mai i te 1 ki te 12. Ka tatau i ngā pikitia, ka tatau rānei i ētahi taonga hei tohu i te rōpere, pēnei i te matimati, i te porotiti rānei.

## Te Taura me te Pānga

Ngā Whāinga		
Ka whakaoti rapanga te ākonga, ka whakamārama otinga, e whai wāhi mai ana:	He taura ēnei o ngā āhuetanga me mātua mōhio te ākonga e tutuki ai tana whakaoti rapanga:	<i>repetitive pattern</i>
<ul style="list-style-type: none"> <li>te hanga me te whakaroa taura tāruarua<sup>6</sup>.</li> </ul>	<ul style="list-style-type: none"> <li>te tautohu i te pūtake o te taura e tāruaruatia ana.</li> </ul>	

## Te Reo Matatini o te Pāngarau

Hei taura kupu		
<ul style="list-style-type: none"> <li>taura</li> <li>whakaroa taura</li> <li>mua</li> </ul>	<ul style="list-style-type: none"> <li>tāruarua</li> <li>e whai mai ana</li> <li>muri</li> </ul>	<ul style="list-style-type: none"> <li>pūtake o te taura</li> <li>hanga taura</li> <li>tuatahi, tuarua, tuatoru ...</li> </ul>

## He Taura Rapanga

Te Taura me te Pānga 1a

### Rapanga 4

**Rauemi:** He huinga poraka āhuetanga ake.

Whakatakotoria kia whā atu anō ngā āhua hei whakaroa i tēnei taura. He aha i pēnā ai tō whakatakoto i ngā āhua?

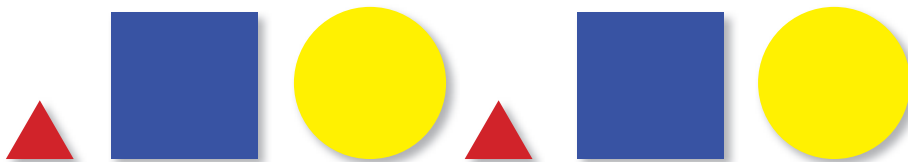

Kia tika te otinga (tapatoru whero iti, tapawhā rite kahurangi nui, porowhita kōwhai nui, tapatoru whero iti), ā, ka tohua te pūtake o te taura e tāruaruatia ana, ka tohua rānei te whai mai o tētahi āhua i tētahi.

Te Taura me te Pānga 1a

### Rapanga 5

**Rauemi:** He kāri kararehe\* – kia toru ngā kau, kia toru ngā kurī, kia toru ngā ngeru, kia toru ngā hipi.

Whakamahia ētahi o ēnei kāri. Hangaia tētahi taura tāruarua. Whakamāramatia mai tō taura. He aha te pūtake o te taura?



Ka hangaia tētahi taura tāruarua, ā, ka whakamāramatia te taura – te whai mai o tētahi kararehe i tētahi, me te pūtake o te taura e tāruaruatia ana.

\*Kei runga i te pae Ipurangi [www.nzmaths.co.nz](http://www.nzmaths.co.nz) ēnei kāri hei tāruatanga.



## Te Ine me te Hanga

Ngā Whāinga		
Ka whakaoti rapanga te ākonga, ka whakamārama otinga, e whai wāhi mai ana:	He tauira ēnei o ngā āhuatanga me mātua mōhio te ākonga e tutuki ai tana whakaoti rapanga:	
<ul style="list-style-type: none"> <li>te whakatairite<sup>7</sup> me te whakaraupapa i te rahi o ngā āhuatanga ine<sup>8</sup> o ētahi mea e rua</li> <li>te whakarōpū taonga i runga anō i ngā āhuatanga hanga<sup>9</sup> o aua taonga.</li> </ul>	<ul style="list-style-type: none"> <li>ēnei āhuatanga e taea ana te ine: te roa, te taumaha, te wā, te paemahana, me te utu</li> <li>te reo māmā hei whakatairite i ngā āhuatanga ine o ētahi mea</li> <li>ēnei momo āhuatanga hanga māmā hei whakarōpū taonga: te rahi, te tae, te maha o ngā kokonga, ngā tapa, me ngā mata.</li> </ul>	<p><sup>7</sup>compare <sup>8</sup>measurement attributes</p> <p><sup>9</sup>geometric properties</p>

## Te Reo Matatini o te Pāngarau

Hei tauira kupu		
<ul style="list-style-type: none"> <li>roa</li> <li>utu</li> <li>ine</li> <li>ake/atu (pēnei i te "roa ake")</li> <li>ngā kupu mō te wā: ata, ahiahi, pō, pouputanga o te rā ...</li> </ul>	<ul style="list-style-type: none"> <li>wā</li> <li>kokonga</li> <li>muri</li> <li>iho (pēnei i te "iti iho")</li> <li>ngā kupu pānui wā karaka: te hāora tauoti me te hāora haurua</li> </ul>	<ul style="list-style-type: none"> <li>taumaha</li> <li>mata</li> <li>tapa</li> <li>whakarōpū</li> <li>whakatairite</li> </ul>
Hei tauira whakaahuahanga		
<ul style="list-style-type: none"> <li>he rārangi wā</li> </ul>	<ul style="list-style-type: none"> <li>he whārite ine-taumaha</li> </ul>	

## He Tauira Rapanga

### Te Ine me te Hanga 1a

#### Rapanga 6

**Rauemi:** He tūru, he tēpu. Kia āhua rite te teitei o te tūru me te roa o te tēpu.

Tohua mai te teitei o te tūru. Tohua mai te roa o te tēpu. Ko tēhea te mea roa ake – ko te teitei o te tūru, ko te roa rānei o te tēpu? He aha koe i mōhio ai?

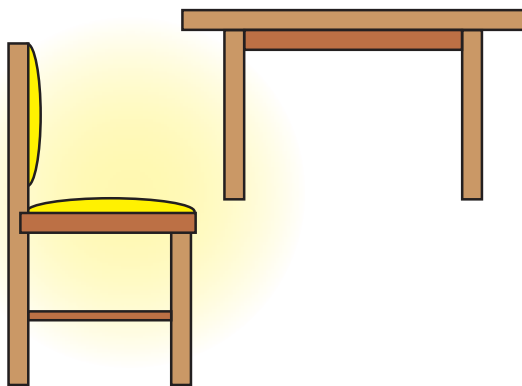

Kia tika te otinga, mā te whakatairite mata ki mata. Hei tauira, ka whakatakotoria pea te tūru ki te taha o te tēpu, kia hāngai tonu tētahi pito o te tūru me tētahi tapa o te tēpu.

### Te Ine me te Hanga 1a

#### Rapanga 7

**Rauemi:** He poi kirikiti, he poi tēnehi, he whārite ine-taumaha.

- Ki tōu whakaaro ko tēhea te mea taumaha ake, ko te poi kirikiti, ko te poi tēnehi rānei?
- Whakamahia te ine-taumaha, kia kitea ai mēnā kei te tika tō whakaaro.

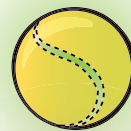

Ka matapaetia te poi taumaha ake, ā, ka tika te whakamahinga o te whārite ine-taumaha hei whakatairite i te taumaha o tēnā me tēnā.

# WHANAKETANGA 1a

## Te Ine me te Hanga 1a

### Rapanga 8

**Rauemi:** He huinga kāri\* e whakaatu ana i ētahi mahi e ono e hāngai ana ki tēnā wāhanga o te rā, ki tēnā (hei tauira: te oho, te parakuihi, te haere ki te kura, te tākaro, te kai o te ahiahi/pō, te hoki ki te moe). He rārangi wā e whakaatu ana i te ono karaka i te ata i tētahi pito me te iwa karaka i te pō i tētahi.

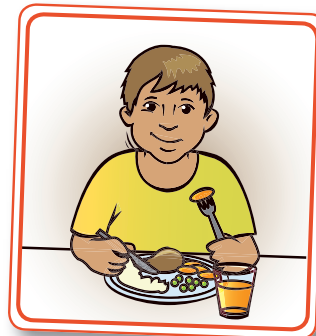

6:00 ata



9:00 pō

He kāri ēnei e whakaatu ana i ngā mahi a Haki i tētahi rā, mai i tana mahi tuatahi o te rā ki tana mahi whakamutunga.

1. Raupapahia ēnei kāri ki te rārangi – ko tana mahi tuatahi ki te taha mauī, ko tana mahi whakamutunga ki te taha matau.
2. Whakamāramatia mai he aha i pēnā ai tō raupapa mai i āna mahi.

**Ka raupapahia ngā kāri me te hāngai anō o ngā whakamārama mō ngā wā e tika ana mō ia mahi.**

## Te Ine me te Hanga 1a

### Rapanga 9

**Rauemi:** He huinga āhua.

Whakarōpūngia ngā āhua. He aha te/ngā mea ōrite o ngā āhua o ia rōpū?



Ka whakarōpūngia ngā āhua, ā, ka tika te whakamārama i te/ngā āhuatanga ōrite o ia rōpū pēnei i: te momo āhua; te rahi; te kōpiko, te torotika rānei o ngā tapa; te maha o ngā tapa; te koi o ngā kokonga.

\*Kei runga i te pae ipurangi [www.nzmaths.co.nz](http://www.nzmaths.co.nz) ēnei kāri hei tāruatanga.

## Te Wāhi, te Ahunga, me te Panoni

Ngā Whāinga		
Ka whakaoti rapanga te ākonga, ka whakamārama otinga, e whai wāhi mai ana:	He tauira ēnei o ngā āhuatanga me mātua mōhio te ākonga e tutuki ai tana whakaoti rapanga:	
<ul style="list-style-type: none"> <li>te whai me te hoatu tohutohu mō te <b>nuku</b><sup>10</sup></li> <li>te whakamārama i te wāhi noho o tētahi mea.</li> </ul>	<ul style="list-style-type: none"> <li>ngā kupu <b>ahunga</b><sup>11</sup> māmā, pēnei i ēnei: whakamua, whakamuri, mauī, matau, me ētahi noa atu</li> <li>ngā kupu whakaatu <b>taunga</b><sup>12</sup> māmā pēnei i ēnei: tata, tawhiti, taha, waenganui, mua, muri, me ētahi noa atu.</li> </ul>	<p><sup>10</sup>movement</p> <p><sup>11</sup>direction</p> <p><sup>12</sup>position</p>

## Te Reo Matatini o te Pāngarau

Hei tauira kupu		
<ul style="list-style-type: none"> <li>whakamua</li> <li>matau</li> <li>heke iho</li> <li>tua mai</li> </ul>	<ul style="list-style-type: none"> <li>whakamuri</li> <li>taha</li> <li>waenganui</li> <li>rahaki</li> </ul>	<ul style="list-style-type: none"> <li>mauī</li> <li>piki ake</li> <li>tua atu</li> <li>tata</li> </ul>
Hei tauira whakaahuahanga		
<ul style="list-style-type: none"> <li>he rārangi tau</li> </ul>	<ul style="list-style-type: none"> <li>he pikitia whakaatu tūwāhi</li> </ul>	

## He Tauira Rapanga

### Te Wāhi, te Ahunga, me te Panoni 1a

#### Rapanga 10

Ka mahi takirua ngā ākonga, ko tētahi hei tuku, ko tētahi hei whai i ngā tohutohu. Ko tā te kaituku, he tohutohu i tana hoa ānō nei he kāpō, kia pai ai tana hīkoi mai i tētahi wāhi o te kura ki tētahi.



Kia tika te whakamahi me te whai i ngā kupu tohutohu pēnei i te whakamua, whakamuri, matau, mauī, me ētahi noa atu.

### Te Wāhi, te Ahunga, me te Panoni 1a

#### Rapanga 11

**Rauemi:** He rārangi tau nui mai i te 0 ki te 20, he huinga poraka āhuatanga ake.

Whakatakatoria te rārangi tau ki te papa, ka tuku ai i ngā tonono e whai ana i ngā kupu tūwāhi pēnei i ēnei:

- E Mara, waihotia he tapatoru iti ki raro i te tau kei waenganui i te whā me te ono.
- E Tama, waihotia he porowhita ki te taha mauī o te tekau mā toru.
- E Hine, waihotia he tapawhā ki tua atu o te rua tekau.
- E Wi, waihotia he tapatoru mātotoru kia pātata atu ki tētahi o ngā tau nui ake i te tekau mā rima.
- ...

Mā ngā ākonga anō hoki e tuku ngā tohutohu.



Kia tika te whakamahi me te whai i ngā kupu tūwāhi.

## Te Tauanga

### Ngā Whāinga

Ka whakaoti rapanga te ākonga, ka whakamārama otinga, e whai wāhi mai ana:

- te whakarōpū raraunga māmā, e hāngai ana ki te ao o te tamaiti.

He tauira ēnei o ngā āhuatanga me mātua mōhio te ākonga e tutuki ai tana whakaoti rapanga:

- ngā momo whakarōpūtanga e taea ana mō tētahi huinga raraunga<sup>13</sup> māmā.

<sup>13</sup>data set

## Te Reo Matatini o te Pāngarau

### Hei tauira kupu

- rōpū
- whakarōpū

### Hei tauira whakaahuahanga

- ngā momo whakaatu huinga

## He Tauira Rapanga

### Te Tauanga 1a

#### Rapanga 12

**Rauemi:** Ngā kāri\* e whakaatu ana i ngā momo hākinakina

Nā ia tamaiti i te akomanga o Whaea Wini i whiriwhiri tētahi kāri hei whakaatu i te hākinakina e tino pai ana ki a rātou. Koia nei te huinga o aua kāri:

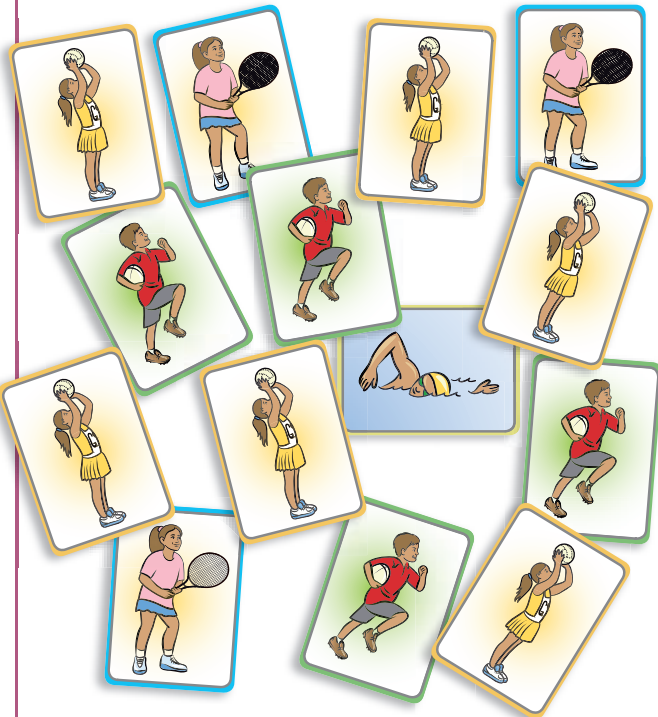

Tokohia te maha ake o ngā tamariki i whiriwhiri i te poitarawhiti i te whutupōro pā?

**Kia tika te otinga (2).** Ākene pea ka whakarōpūngia ngā hākinakina, ā, ka taturia te maha o ngā kāri poitarawhiti me te maha o ngā kāri whutupōro pā. Ka whakatakatoria rānei ngā kāri poitarawhiti ki te taha o ngā kāri whutupōro pā, kia āta kitea e rua te nui ake o ngā poitarawhiti i ngā whutupōro pā.

### Te Tauanga 1a

#### Rapanga 13

**Rauemi:** Ngā kāri e whakaatu ana i ngā hākinakina nei:



Whakarōpūngia ēnei hākinakina.  
Whakamāramatia mai ō rōpū hākinakina.

**Kia whakarōpūngia ngā hākinakina, me te whakamārama i ngā āhuatanga ake o tēnā me tēnā o ngā rōpū.**

Hei tauira:

- me whiwhi pōro mō ēnei hākinakina
- he hākinakina ā-tīma ēnei
- he hākinakina takitahi ēnei
- ka tākarohia ēnei hākinakina i tētahi pātiki
- ka tākarohia ēnei hākinakina i te papa mārō.

\*Kei runga i te pae Ipurangi [www.nzmaths.co.nz](http://www.nzmaths.co.nz) ēnei kāri hei tāruatanga.

## Te Tau: Te Mātauranga Tau me ngā Rautaki Tau

(TPT) Kaupae 3–4

Ngā Whāinga		
Ka whakaoti rapanga te ākonga, ka whakamārama otinga, e whai wāhi mai ana:	He tauira ēnei o ngā āhuatanga me mātua mōhio te ākonga e tutuki ai tana whakaoti rapanga:	
<ul style="list-style-type: none"> <li>ngā rautaki tatau māwhitiwhiti<sup>1</sup>, ngā rautaki tatau ake<sup>2</sup>, me ngā rautaki tohatoha ōrite<sup>4</sup> hei whakaoti paheko tau.</li> </ul>	<ul style="list-style-type: none"> <li>ngā tauoti mai i te 0 ki te 100 me te mātauranga uara tū<sup>3</sup> e hāngai ana</li> <li>te tatau mawhiti-2, mawhiti-5, mawhiti-10, whakamua, whakamuri hoki</li> <li>ngā meka tāpiritanga ki te 10 me ngā tangohanga e whai pānga ana</li> <li>ngā tau rearua ki te 20 me ngā haurua e whai pānga ana</li> <li>te whakaatu paheko tau<sup>5</sup> hei whārite<sup>6</sup></li> <li>ngā kupu, ngā tohu, ngā whakaahuahanga<sup>7</sup> me te tikanga o ngā haurua me ngā hauwhā.</li> </ul>	<ul style="list-style-type: none"> <li><sup>1</sup>skip count strategy</li> <li><sup>2</sup>count on</li> <li><sup>3</sup>place value</li> <li><sup>4</sup>equal sharing strategy</li> <li><sup>5</sup>number operation</li> <li><sup>6</sup>equation</li> <li><sup>7</sup>representation</li> </ul>

## Te Reo Matatini o te Pāngarau

Hei tauira kupu			
• tatau māwhitiwhiti	• tatau mawhiti-2, mawhiti-5 ...	• tatau ake	• taukehe
• tāpiri	• tango	• tohatoha	• taurua
• rōpū, whakarōpū	• rearua	• haurua, hauwhā	
• whārite	• tohu	• ōrite	
Hei tauira tohu			
• x	• ÷	• $\frac{1}{2}, \frac{2}{2}, \frac{3}{2}...$	• $\frac{1}{4}, \frac{2}{4}, \frac{3}{4}, \frac{4}{4}...$
Hei tauira whakaahuahanga			
• he rārangi tau	• he porowhita hei tohu huinga	• he anga tekau	• he anga pīrepire

## He Tauira Rapanga

Te Tau 1e

### Rapanga 1

I haere a Pāpā ki te tiki i ana tāruke e rua. E 5 ngā kōura i tētahi o ngā tāruke, e 8 i tētahi. E hia katoa ana kōura?



Kia tika te otinga (13), mā te tatau ake i te 8 ki te 13. Ka tatau ā-hinengaro, ka tatau rānei i ētahi taonga hei tohu i ngā kōura, pēnei i te matimati, i te porotiti rānei.

Te Tau 1e

## Rapanga 2

\$100 te pūtea a Wini. Ka pau i a ia te \$30. E hia tāra e toe mai ana?

Kia tika te otinga (\$70), mā te tatau mawhiti-10 whakamuri, mā te whakamahi meka tangohanga rānei ( $10 - 3 = 7$ ).

Te Tau 1e

## Rapanga 3

E 8 ngā āporo kei roto i te kumete. Nā Kui i mau mai ētahi āporo anō. Hui katoa ka 16 ngā āporo. E hia ngā āporo nā Kui i mau mai?

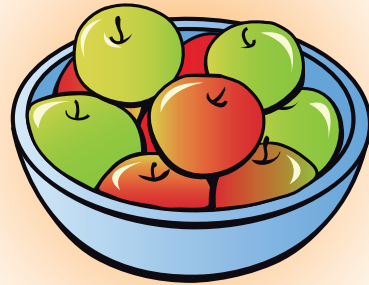

Kia tika te otinga (8), mā te mōhio ki ngā tau rearua.

Te Tau 1e

## Rapanga 4

12 ngā kōura ka tohaina ki ētahi whānau e 4, kia ōrite te whiwhinga a tēnā whānau, a tēnā. E hia ngā kōura ka tohaina ki ia whānau?

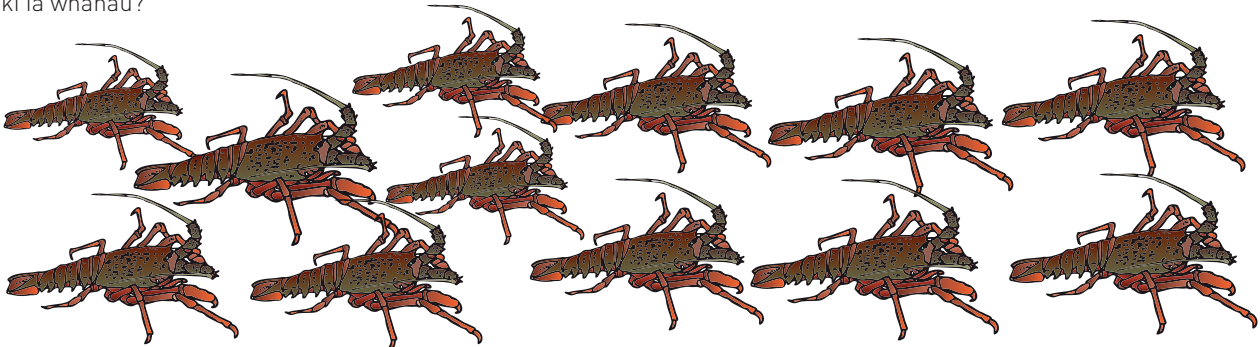

Kia tika te otinga (3), mā te tuhi pikitia, mā te tohatoha porotiti hei tohu i ngā kōura, mā te whakamahi rānei i ngā tau rearua ( $12 = 6 + 6 = 3 + 3 + 3 + 3$ ).

Te Tau 1e

## Rapanga 5

**Rauemi:** He pepa tapawhā rite te āhua.

Me pēhea te whakaatu i te hauwhā o tēnei pepa?

Whakaaturia mai kia rua ngā hauwhātanga rerekē.

He aha te tohu mō tētahi wāhanga kotahi o te pepa?

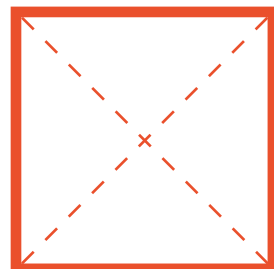
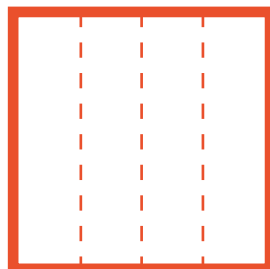
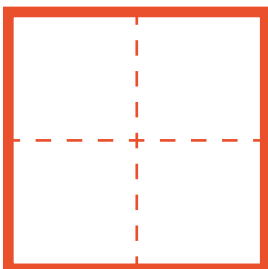

Kia tika te whētui i te pepa, te tuhi rārangi rānei hei whakaatu i ētahi whakahauwhātanga rerekē o te tapawhā rite, arā, kia ōrite te rahi o ia wāhanga. Kia tika hoki te tuhi i te tohu mō te kotahi hauwhā ( $\frac{1}{4}$ ).

## Te Taura me te Pānga

Ngā Whāinga		
Ka whakaoti rapanga te ākonga, ka whakamārama otinga, e whai wāhi mai ana:	He taura ēnei o ngā āhutatanga me mātua mōhio te ākonga e tutuki ai tana whakaoti rapanga:	
<ul style="list-style-type: none"> <li>te hanga me te whakaroa taura raupapa āhuahanga<sup>8</sup>, taura raupapa tau<sup>9</sup> hoki</li> <li>te hanga me te whakaroa taura tāruarua, e rua ōna āhutatanga taurangi<sup>11</sup></li> <li>te whiriwhiri huānga<sup>12</sup> o roto i tētahi taura tāruarua māmā.</li> </ul>	<ul style="list-style-type: none"> <li>te tipu o te taura raupapa, me te pūmautanga<sup>10</sup> o te tipu.</li> </ul>	<p><sup>8</sup>sequential geometric pattern</p> <p><sup>9</sup>sequential number pattern</p> <p><sup>10</sup>invariance</p> <p><sup>11</sup>variable</p> <p><sup>12</sup>element</p>

## Te Reo Matatini o te Pāngarau

Hei taura kupu					
• taura raupapa	• ture	• huānga	• tipu o te taura	• whakaroa taura	• hanga taura

## He Taura Rapanga

### Te Taura me te Pānga 1e

#### Rapanga 6

Tuhia kia toru atu anō ngā tau o tēnei taura raupapa.

**24, 27, 30, 33...**

He aha tō mahi hei whiriwhiri i ngā tau o tēnei taura raupapa?

Tuhia he whārite hei whakaatu i tō whiriwhiringa i tētahi o ngā tau.

Kia tika te otinga (36, 39, 42), me te whakamārama i te ture o te raupapa, arā, ko te tāpiri i te 3. Kia tika hoki te tuhi i te whārite e hāngai ana ki tētahi o ngā whiriwhiringa. Hei taura  $36 + 3 = 39$ .

### Te Taura me te Pānga 1e

#### Rapanga 7

**Rauemi:** He porotiti whai kano

Whakamahia ngā porotiti hei hanga i tētahi taura tāruarua, kia whero te huānga tuawaru o te taura.

He aha te pūtake o te taura?

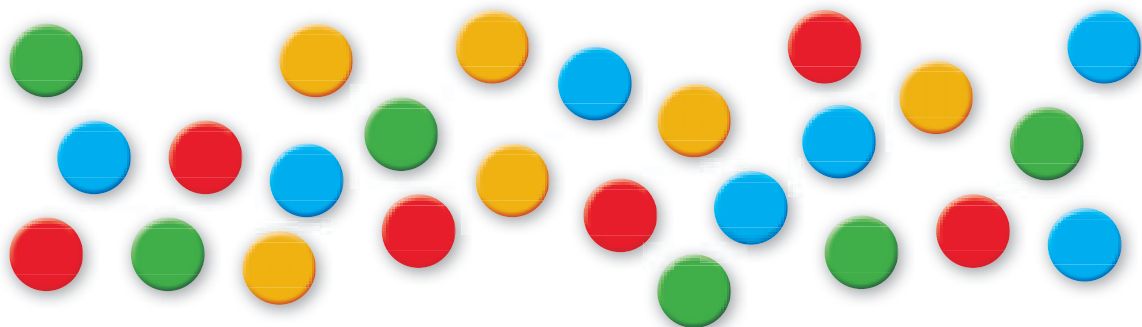

Kia tika te hanga i tētahi taura me te whiriwhiri kia whero te huānga tuawaru. Ka whakaaturia te pūtake o te taura, te wāhanga e tāruaruatia ana.

## Te Ine me te Hanga

Ngā Whāinga		
Ka whakaoti rapanga te ākonga, ka whakamārama otinga, e whai wāhi mai ana:	He tauira ēnei o ngā āhuetanga me mātua mōhio te ākonga e tutuki ai tana whakaoti rapanga:	
<ul style="list-style-type: none"> <li>te whakamahi waeine aro kē<sup>13</sup> hei ine i tētahi mea</li> <li>te whakamahi waeine aro whānui<sup>14</sup> māmā hei ine i tētahi mea</li> <li>ngā āhuetanga hanga<sup>15</sup> o ngā taparau<sup>16</sup> māmā me ngā matarau<sup>17</sup> māmā</li> </ul>	<ul style="list-style-type: none"> <li>ēnei āhuetanga e taea ana te ine – te hurihanga, te rōrahi/kītanga, me te horahanga</li> <li>te pūmautanga o te waeine</li> <li>te tāruarua<sup>18</sup> i te waeine hei ine i tētahi mea, kāore he āputa<sup>19</sup>, kāore e inaki<sup>20</sup> rānei</li> <li>te wāhi tīmata me te wāhi mutu o tētahi inenga</li> <li>ngā ingoa o ngā āhua ahu-2<sup>21</sup> māmā me ngā āhua ahu-3<sup>22</sup> māmā [pērā i te tapatoru, te tapawhā, te taimana, te porowhita, te tapawhā rite, te tapawhā hāngai, te pouaka, me te poi].</li> </ul>	<p><sup>13</sup>non-standard unit</p> <p><sup>14</sup>standard unit</p> <p><sup>15</sup>geometric properties</p> <p><sup>16</sup>polygon</p> <p><sup>17</sup>polyhedron</p> <p><sup>18</sup>repeating</p> <p><sup>19</sup>gap</p> <p><sup>20</sup>overlap</p> <p><sup>21</sup>2-dimensional shape</p> <p><sup>22</sup>3-dimensional shape</p>

## Te Reo Matatini o te Pāngarau

Hei tauira kupu		
<ul style="list-style-type: none"> <li>waeine</li> <li>kītanga</li> <li>tapawhā</li> <li>tapawhā rite</li> </ul>	<ul style="list-style-type: none"> <li>hurihanga</li> <li>horahanga</li> <li>taimana</li> <li>tapawhā hāngai</li> </ul>	<ul style="list-style-type: none"> <li>rōrahi</li> <li>tapatoru</li> <li>porowhita</li> </ul>

## He Tauira Rapanga

### Te Ine me te Hanga 1e

#### Rapanga 8

Whiriwhiria tētahi waeine aro kē e tika ana hei ine i ngā mea nei:

- te roa o tētahi pene
- te whānui o tētahi pukapuka
- te teitei o tētahi tūru
- te whānui o te akomanga
- te roa o te papa tākaro whutupōro.

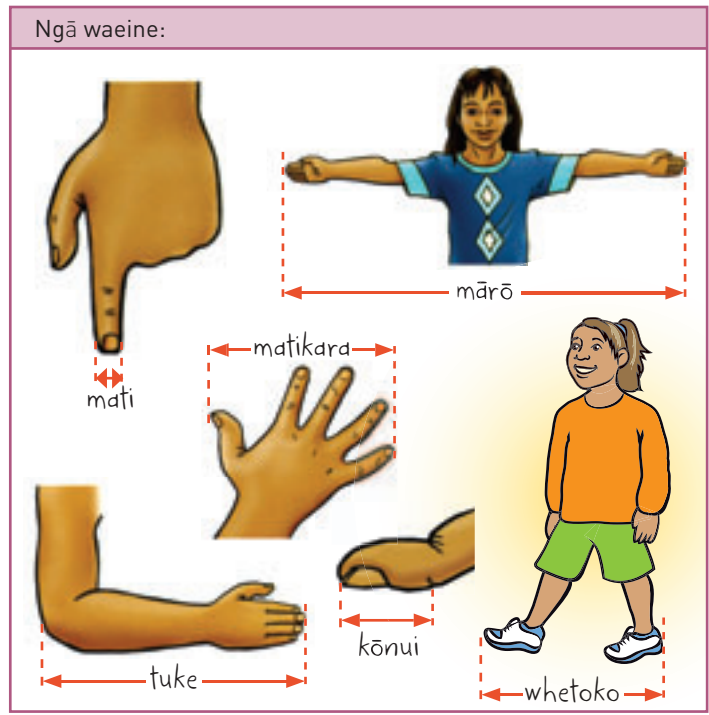



Me whakatau tata i te tuatahi, kātahi ka ine i ngā mea nei. Whakaotia te tūtohi nei:

Te mea hei ine	Te waeine	Te whakataunga tata	Te inenga
te roa o tētahi pene			
te whānui o tētahi pukapuka			
te teitei o tētahi tūru			
te whānui o te akomanga			
te roa o te papa tākaro whutupōro			

**Ka whiriwhiria ngā waeine e tika ana me te whakamārama anō he aha i tika ai. Ka whakatau tata i ngā inenga, ā, ka tika te tāruarua me te tatau i ngā waeine.**

## Te Ine me te Hanga 1e

### Rapanga 9

**Rauemi:** Kia 23 ngā mataono honohono.

E hia ngā mataono honohono kia ōrite ki te teitei o te tūru?

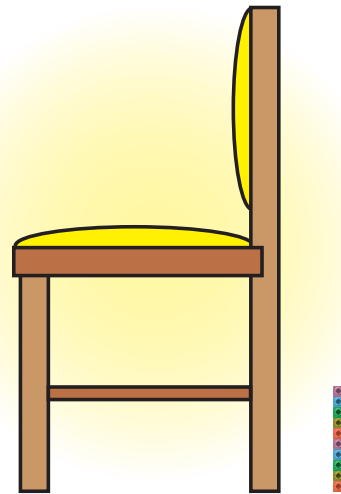

**Ka hanga te ākonga i tētahi waeine, pēnei i ngā mataono 10.  
Kia tika te whakamahinga o tēnei waeine hei ine i te teitei o te tūru.**

## Te Ine me te Hanga 1e

### Rapanga 10

**Rauemi:** He huinga āhua ahu-2 pēnei i ēnei:

Hoatu he tohutohu hei whakarōpū mā ngā ākonga i ngā āhua ahu-2. Hei tauira:

- Whakarōpūngia ki konei ngā tapawhā katoa.
- Whakarōpūngia ki konei ngā āhua tapa kōpiko.
- Kimihia ngā āhua katoa e toru ngā kokonga, e whā ngā tapa torotika. (Kia mataara: kāore e taea tētahi āhua pēnei.)

**Kia tika te whakarōpū i ngā āhua hei whakaatu i te mārama ki ngā āhua ahu-2 nei me ō rātou āhuatanga hanga, pēnei i ēnei:**

āhua ahu-2: tapawhā, tapawhā rite, tapawhā hāngai, tapatoru, tapaono, porowhita, taimana

āhuatanga hanga: tapa, tapa torotika, tapa kōpiko, kokonga

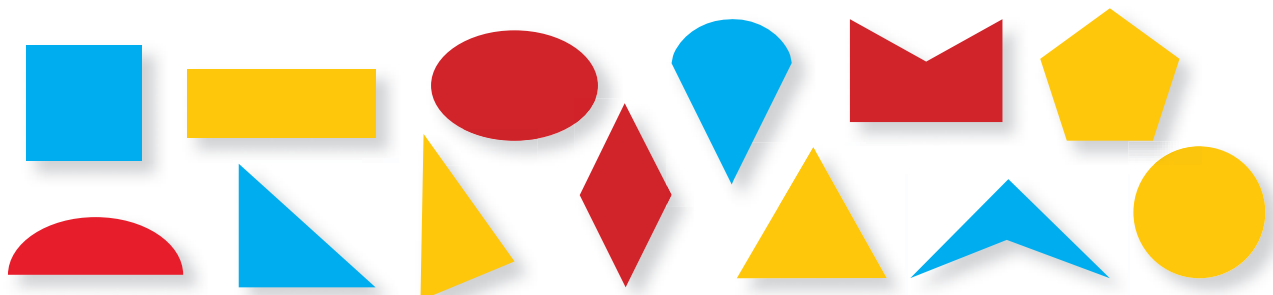

## Te Wāhi, te Ahunga, me te Panoni

Ngā Whāinga		
Ka whakaoti rapanga te ākonga, ka whakamārama otinga, e whai wāhi mai ana:	He tauira ēnei o ngā āhuatanga me mātua mōhio te ākonga e tutuki ai tana whakaoti rapanga:	
<ul style="list-style-type: none"> <li>te whai me te hoatu tohutohu mō te hurihanga</li> <li>te tautohu i te whakaatanga, te hurihanga me te nekenga, o tētahi āhua māmā.</li> </ul>	<ul style="list-style-type: none"> <li>te hurihanga whakatekaraka, te hurihanga <b>kōaro</b><sup>23</sup>, me ngā hurihanga hautanga māmā (<math>\frac{1}{4}, \frac{2}{4}, \frac{3}{4}, \frac{4}{4}, \frac{5}{4} \dots</math>)</li> <li>ngā āhuatanga ka noho pūmau<sup>24</sup> i te panoni<sup>25</sup> māmā.</li> </ul>	<p><sup>23</sup>anti-clockwise</p> <p><sup>24</sup>invariant</p> <p><sup>25</sup>transformation</p>

## Te Reo Matatini o te Pāngarau

Hei tauira kupu		
<ul style="list-style-type: none"> <li>huri, hurihanga</li> <li>hurihanga haurua</li> <li>ahu, ahunga</li> <li>hurihanga kōaro</li> </ul>	<ul style="list-style-type: none"> <li>hurihanga hauwhā</li> <li>aro, aronga</li> <li>hurihanga whakatekaraka</li> <li>hurihanga toru hauwhā</li> </ul>	<ul style="list-style-type: none"> <li>neke, nekenga</li> <li>poutū</li> <li>huapae</li> <li>huripoki, kauhuri, whakaata</li> </ul>

## He Tauira Rapanga

### Te Wāhi, te Ahunga, me te Panoni 1e

#### Rapanga 11

**Rauemi:** He tauira tangata, he rākau Ātaarangi.

Whakatūria te tauira tangata ki te pokapū o te papa, me ētahi rākau rerekē ki ngā ahunga matua e whā. Tukuna he pātai pēnei i ēnei mō te hurihanga:

- I te tīmatanga e aro ana a Timi ki te rākau whero. Mēnā kotahi hauwhā tana hurihanga whakatekaraka, ka aro atu ia ki tēhea rākau?
- E aro ana a Timi ki te rākau kahurangi. E toru haurua tana hurihanga kōaro. E aro atu ana ia ki tēhea rākau ināianei?
- E aro ana a Timi ki te rākau kōwhai. Pēhea nei te rahi me te ahunga o tana hurihanga kia aro atu ia ki te rākau pango?
- E aro ana a Timi ki te rākau pango. He aha ō tohutohu ki a ia kia noho mai ko te rākau whero kei mua i tana aroaro?
- Whakaaturia mai te hurihanga rima hauwhā.

**Kia tika te whakamahi i ngā rauemi hei whakaatu i ngā hurihanga, ka whakaoti rānei mā te whakaahua ā-hinengaro.**

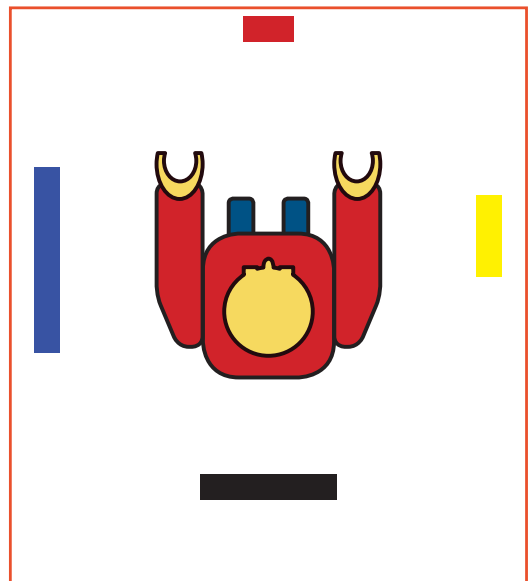

### Te Wāhi, te Ahunga, me te Panoni 1e

#### Rapanga 12

Mēnā e taea ana, tuhia he rārangi hei whakahaurua i ēnei āhua kia ōrite ngā taha e rua o te āhua. Mēnā e rua, nui ake rānei ngā rārangi e taea ana hei whakahaurua i te āhua, tuhia aua rārangi katoa.

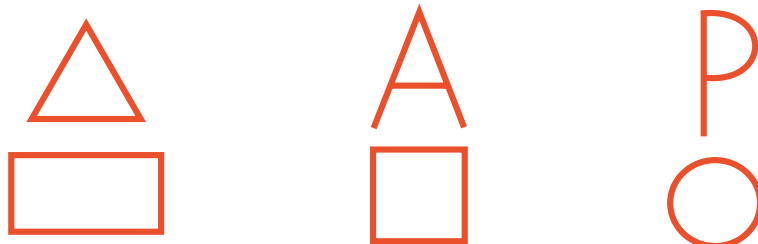

**Kia tika te tuhi i ngā rārangi hangarite, me te tautohu i ngā āhua karekau he rārangi hangarite.**

## Te Tauanga

Ngā Whāinga		
Ka whakaoti rapanga te ākonga, ka whakamārama otinga, e whai wāhi mai ana:	He tauira ēnei o ngā āhuatanga me mātua mōhio te ākonga e tutuki ai tana whakaoti rapanga:	
<ul style="list-style-type: none"> <li>te hanga me te whakamāori<sup>26</sup> whakaari raraunga<sup>27</sup> māāmā, pēnei i te kauwhata whakaahua.</li> </ul>	<ul style="list-style-type: none"> <li>te tatau raraunga whakarōpū<sup>28</sup> hei whakaputa kōrero mō tētahi huinga raraunga</li> <li>te tikanga o te whakamahi whakaahua hei tohu raraunga.</li> </ul>	<p><sup>26</sup>interpret</p> <p><sup>27</sup>data display</p> <p><sup>28</sup>category data</p>

## Te Reo Matatini o te Pāngarau

Hei tauira kupu		
<ul style="list-style-type: none"> <li>kauwhata whakaahua</li> <li>tūtohi</li> </ul>	<ul style="list-style-type: none"> <li>raraunga</li> <li>ngā kupu whakatairite pērā i te poto iho, te roa ake ...</li> </ul>	<ul style="list-style-type: none"> <li>huinga raraunga</li> </ul>
Hei tauira whakaahuahanga		
<ul style="list-style-type: none"> <li>kauwhata whakaahua</li> </ul>	<ul style="list-style-type: none"> <li>tūtohi</li> </ul>	

## He Tauira Rapanga

### Te Tauanga 1e

### Rapanga 13

Ka mahi takirua ngā ākonga ki te kohikohi kia tekau ngā rau rākau rerekē. Ka whakawhitiwhiti kōrero ia takirua mō ētahi whakarōpūtanga o ngā rau.

- Ka whakamārama i ētahi whakarōpūtanga e rua.
- Ka whakaatu i tētahi o ngā whakarōpūtanga ki te kauwhata whakaahua.
- Ka whakaputa kōrero, ka whakautu pātai mō ngā raraunga ka whakaaturia ki te kauwhata whakaahua.

Kia pai te āhua o te tiki rau rākau me te manaaki anō i te taiao.

Kia pai te whai wāhi mai o ngā ākonga ki te whakawhitiwhiti whakaaro me te whakatauri i ētahi whakarōpūtanga o ngā rau rākau. Hei tauira, ko te rahi o ngā rau; ko te tae o ngā rau; ko te āhua o ngā rau (pērā i te roa, te whānui, te koi ...); ko te kakano o ngā rau (pērā i te māeneene, te mārō, te taratara ...); te momo rākau (pērā i te rākau māori, te rākau rāwaho).



Kia tika te whakaatu i tētahi o ngā whakarōpūtanga ki te kauwhata whakaahua.

Kia tika te whakaputa kōrero, te whakautu pātai rānei mō te kauwhata whakaahua. Hei tauira:

- E whā ngā rau he poto iho i taku kōnui.
- E toru te maha ake o ngā rau māeneene i ngā rau mārō.

## Te Tūponotanga

Ngā Whāinga		
Ka whakaoti rapanga te ākonga, ka whakamārama otinga, e whai wāhi mai ana:	He tauira ēnei o ngā āhuatanga me mātua mōhio te ākonga e tutuki ai tana whakaoti rapanga:	
<ul style="list-style-type: none"> <li>te tūhura i ētahi pūāhua tūponotanga<sup>29</sup> māmā;</li> <li>te matapae<sup>30</sup> me te whakamātau<sup>31</sup> i ngā putanga<sup>32</sup> o tētahi pāpono tūponotanga<sup>33</sup>.</li> </ul>	<ul style="list-style-type: none"> <li>ngā putanga ka taea i tētahi pāpono tūponotanga.</li> </ul>	<sup>29</sup> probability situation <sup>30</sup> predict <sup>31</sup> trial <sup>32</sup> outcome <sup>33</sup> probability event

## Te Reo Matatini o te Pāngarau

Hei tauira kupu		
• matapae	• whakamātau	• putanga

## He Tauira Rapanga

### Te Tūponotanga 1e

### Rapanga 14

Kuhuna ētahi porotiti e ono ki tētahi pēke, ko tētahi he kōwhai te tae, e rima he whero.

Tukuna he pātai mō te tango matapōkere i tētahi o ngā porotiti. Hei tauira:

- Mēnā ka tango au i tētahi o ngā porotiti, kāore aku tiroiro, ki tōu whakaaro, he aha te tae o te porotiti ka tangohia? He aha i pērā ai ō whakaaro?
- Pēhea nei ō whakaaro mō te tango mai i te porotiti kōwhai?
- Pēhea nei ō whakaaro mō te tango mai i te porotiti kahurangi?
- Māu e whakamātau. Kia tekau ngā tangohanga porotiti. Ki tō whakaaro, ka hia ngā tangohanga porotiti kōwhai, ka hia hoki ngā tangohanga porotiti whero?

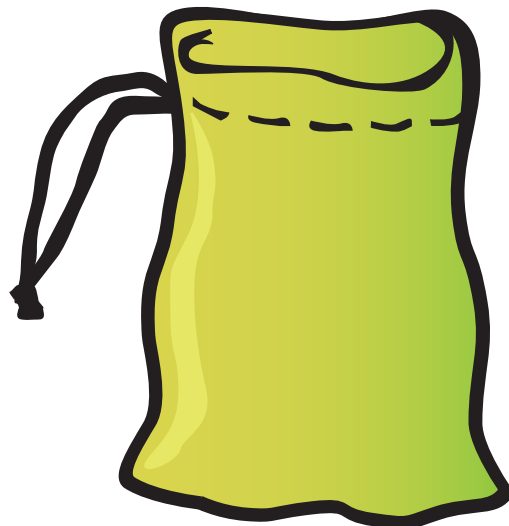
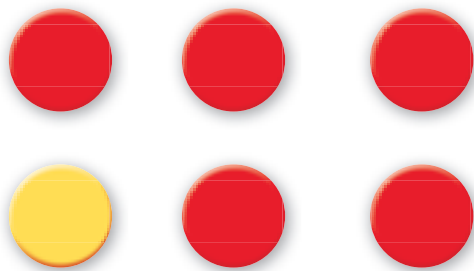

Kia mōhio te ākonga ki ngā putanga e taea ana me te mōhio anō mēnā ka tino eke tētahi putanga, ākene pea ka eke, e kore rawa rānei e eke. Hei tauira whakautu ki ngā pātai:

- Ākene pea he whero te tae nā te mea he maha kē atu ngā porotiti whero kei roto i te pēke.
- He waimarie nā te mea kotahi anake te porotiti kōwhai.
- Kāore e taea te porotiti kahurangi nā te mea he kōwhai, he whero anake ngā tae kei roto i te pēke.
- Kia tika te whakamātau i te tangohanga porotiti, me te tuhi anō i ngā putanga o ia tangohanga. Kia tika hoki te matapae, kāore e kore he nui ake ngā tangohanga porotiti whero.

## Te Tau: Te Mātauranga Tau me ngā Rautaki Tau

(TPT) Kaupae 5

Ngā Whāinga		
Ka whakaoti rapanga te ākonga, ka whakamārama otinga, e whai wāhi mai ana:	He tauira ēnei o ngā āhuratanga me mātua mōhio te ākonga e tutuki ai tana whakaoti rapanga:	
<ul style="list-style-type: none"> <li>ngā rautaki wāwāhi tau<sup>1</sup> māmā hei whakaoti paheko tau.</li> </ul>	<ul style="list-style-type: none"> <li>ngā tauoti mai i te 0 ki te 1 000, me te mātauranga uara tū<sup>2</sup> e hāngai ana</li> <li>ngā hautau māmā</li> <li>ngā meka tāpiritanga ki te 20 me ngā tangohanga e whai pānga ana</li> <li>te raupapa hautau māmā mēnā he ōrite te tauraro<sup>3</sup>.</li> </ul>	<sup>1</sup> part-whole strategies <sup>2</sup> place value   <sup>3</sup> denominator

## Te Reo Matatini o te Pāngarau

Hei tauira kupu		
<ul style="list-style-type: none"> <li>wāwāhi</li> <li>hautau</li> <li>tango</li> </ul>	<ul style="list-style-type: none"> <li>rautaki</li> <li>haurua, hauroru, hauwhā, hauwaru</li> <li>otinga</li> </ul>	<ul style="list-style-type: none"> <li>tau māmā</li> <li>tāpiri</li> </ul>
Hei tauira tohu		
<ul style="list-style-type: none"> <li>ngā tohu hautau</li> </ul>		
Hei tauira whakaahuahanga		
<ul style="list-style-type: none"> <li>he anga tekau</li> </ul>	<ul style="list-style-type: none"> <li>he rārangi tau</li> </ul>	<ul style="list-style-type: none"> <li>he anga pīrepire</li> </ul>

## He Tauira Rapanga

Te Tau 2a

### Rapanga 1

E 2 ngā tūranga pukapuka. E 27 ngā pukapuka kei tētahi o ngā tūranga, e 8 kei tētahi. E hia katoa ngā pukapuka?



Kia tika te otinga (35), mā tētahi rautaki wāwāhi tau ā-hinengaro, me te hāngai anō o te whakamārama. Hei tauira:

1

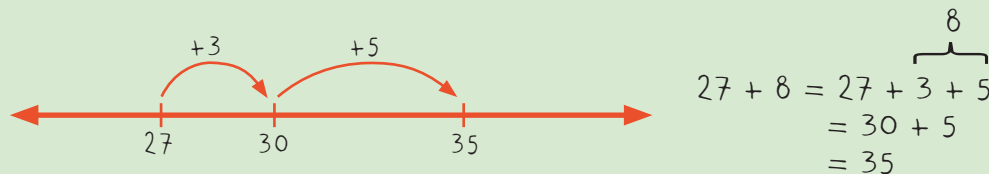

Ka wāwāhia te 8 ki te 3 me te 5. Ka tāpiria te 3 ki te 27, ka 30, kātahi ka tāpiria te 5 kia tae atu ki te 35.

2

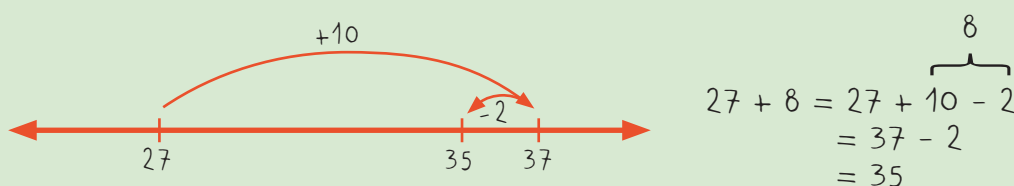

Ka tāpiria te 10 ki te 27, ka 37. He tau māmā te 10. Ināianei, ka tangohia te 2, ka 35.

## Te Tau 2a

### Rapanga 2

E 84 katoa ngā pukapuka kei te tūranga pukapuka.  
E 8 ka tangohia e Whaere Mere hei pānuitanga mā tōna akomanga. E hia ngā pukapuka kei runga tonu i te tūranga?

**Kia tika te otinga (76), mā tētahi rautaki wāwāhi tau ā-hinengaro, me te hāngai anō o te whakamārama: Hei tauira:**

1

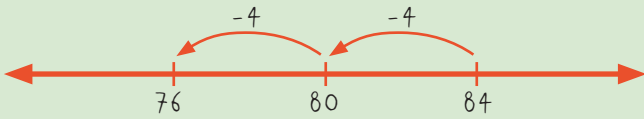

Ka wāwāhia te 8 ki te 4 me te 4. Ka tangohia tētahi o ngā 4 i te 84, ka 80, kātahi ka tangohia tērā atu 4, ka 76.

2

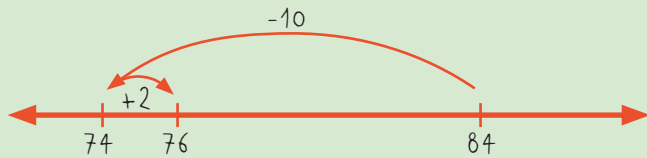

Ka tangohia te 10 i te 84, nā te mea he tau māmā te 10, kātahi ka tāpiria te 2, nā te mea koirā te rerekētanga o te 8 me te 10.



## Te Tau 2a

### Rapanga 3

E 4 ngā tūranga, e 6 ngā pukapuka kei ia tūranga.  
E hia katoa ngā pukapuka?

**Kia tika te otinga (24), mā tētahi rautaki ā-hinengaro, me te hāngai anō o te whakamārama. He tauira:**

$$\begin{aligned} 6 \times 4 &= (6 + 6) + (6 + 6) \\ &= 12 + 12 \\ &= 24 \end{aligned}$$

Ka tāpiria te 6 me te 6, ka 12. Ka tāpiria te 12 me te 12, ka 24.



# WHANAKETANGA 2a

## Te Taura me te Pānga

Ngā Whāinga		
Ka whakaoti rapanga te ākonga, ka whakamārama otinga, e whai wāhi mai ana:	He tauira ēnei o ngā āhuetanga me mātua mōhio te ākonga e tutuki ai tana whakaoti rapanga:	
<ul style="list-style-type: none"> <li>ngā tauira o roto i te wāwāhitanga tāpiripiri<sup>4</sup> o tētahi tau</li> <li>te whakaatu pānga māmā<sup>7</sup></li> <li>ngā tauira ka puta i te wāwāhi āhua</li> <li>te whakamahi rauemi kē hei hanga tauira tāruarua e rite ana ki tētahi atu.</li> </ul>	<ul style="list-style-type: none"> <li>ngā tauira o roto i ngā momo whakaahuahanga<sup>5</sup> tau, pēnei i te anga tekau<sup>6</sup>, te paparau, te anga pīrepire<sup>8</sup>, me te rārangi tau</li> <li>ngā momo whakaahuahanga pānga (pērā i te hoahoa pere<sup>9</sup> me te tūtohi<sup>10</sup>)</li> <li>ngā tauhono takirua<sup>11</sup> o roto i tētahi tau.</li> </ul>	<p><sup>4</sup>additive partitioning</p> <p><sup>5</sup>representation</p> <p><sup>6</sup>tens frame</p> <p><sup>7</sup>simple relationship</p> <p><sup>8</sup>slavonic abacus</p> <p><sup>9</sup>arrow diagram</p> <p><sup>10</sup>table</p> <p><sup>11</sup>additive pairs</p>

## Te Reo Matatini o te Pāngarau

Hei tauira kupu		
<ul style="list-style-type: none"> <li>whētui</li> <li>hautau</li> <li>tango</li> </ul>	<ul style="list-style-type: none"> <li>tauira</li> <li>haurua, hatoru, hauwhā, hauwaru</li> <li>otinga</li> </ul>	<ul style="list-style-type: none"> <li>pānga</li> <li>tāpiri</li> </ul>
Hei tauira whakaahuahanga		
<ul style="list-style-type: none"> <li>hoahoa pere</li> </ul>	<ul style="list-style-type: none"> <li>anga pīrepire</li> </ul>	<ul style="list-style-type: none"> <li>paparau</li> </ul>

## He Tauira Rapanga

### Te Taura me te Pānga 2a

### Rapanga 4

Tekau mā tahi katoa ngā pāua i mau i a Hine rāua ko Tama. He aha ngā whiringa mō te maha o ngā pāua i mau i a Hine me te maha i mau i a Tama?

Tuhia he pikitia hei whakaatu i ngā wāwāhitanga katoa o te 11 e taea ana, kia rua ngā wāhanga. He aha ngā tauira e kitea mai ana?

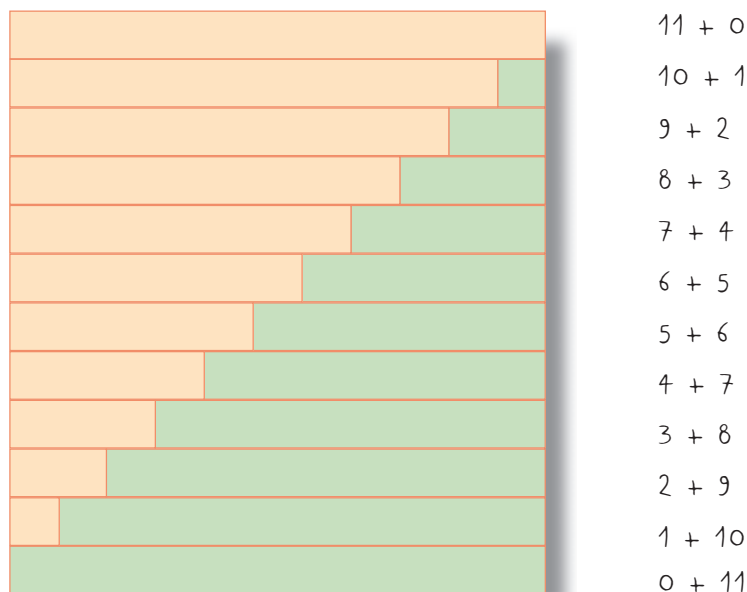

Ka whakaaturia ngā tauhono takirua o te 11 me ētahi whakamārama pēnei:

- Ka piki haere tētahi o ngā tauhono, ka heke haere tētahi.
- Ko tētahi o ngā tauhono he tatau whakamuri mai i te 11 ki te 0. Ko tētahi he tatau whakamua mai i te 0 ki te 11.
- Ka huri kōaro ia tāpiritanga pēnei i te  $10 + 1$  me te  $1 + 10$ .

## Te Taura me te Pānga 2a

### Rapanga 5

*Rauemi:* He huinga kāri kararehe.

He taura tāruarua tēnei.

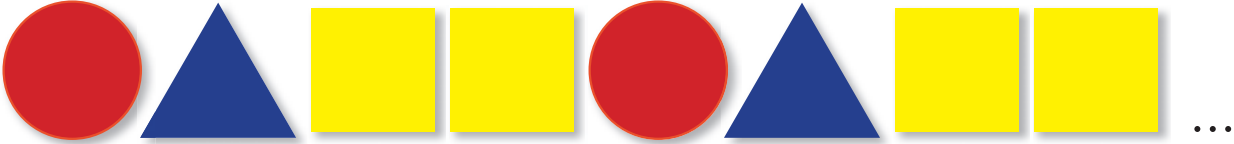

Tohua mai te wāhanga o te taura e tāruaruatia ana.

Whakamahia ēnei kāri kararehe hei hanga i tētahi taura e rite ana.

Whakamāramatia mai te hononga o ngā taura e rua.

**Kia tika te tohu i te pūtaketake o te taura.**

**Kia tika hoki te hanga i tētahi taura e rite ana. Hei taura:**



E hāngai ana te kāri kau ki te porowhita, koia te tīmatanga o te taura. E hāngai ana te kāri kurī ki te tapatoru, koia te kāri tuarua. E hāngai ana te kāri hipi ki te tapawhā rite, koia te kāri tuatoru me te tuawhā. Ko aua kāri e whā ka tāruaruatia hei whakaputa i te taura.



## Te Ine me te Hanga

Ngā Whāinga		
Ka whakaoti rapanga te ākonga, ka whakamārama otinga, e whai wāhi mai ana:	He tauira ēnei o ngā āhuatanga me mātua mōhio te ākonga e tutuki ai tana whakaoti rapanga:	
<ul style="list-style-type: none"> <li>te hanga me te whakamahi taputapu ine, waeine<sup>12</sup> hoki e whaitake ana</li> <li>te wāwāhi me te tāpiri inenga</li> <li>te whakaputa whakaaro mō te whaitakenga<sup>15</sup> o tētahi inenga, i runga anō i ngā whakataunga tata<sup>16</sup></li> <li>ngā āhuatanga hanga<sup>17</sup> o ngā taparau whānui me ngā matarau whānui.</li> </ul>	<ul style="list-style-type: none"> <li>te rahinga āwhiwhi<sup>13</sup> o ngā waeine aro whānui māmā me te hononga ki te rahi o tētahi mea e tino mōhiohia ana (pērā i te roa o te whetoko<sup>14</sup> me te rōrahi o tētahi ipu miraka)</li> <li>ngā hautanga māmā o tētahi waeine</li> <li>ngā momo tapatoru</li> <li>ngā kupu āhuahanga e hāngai ana (pērā i te akitu, te mata, me te tapa)</li> <li>ngā momo matarau<sup>18</sup> (pērā i ngā poro<sup>19</sup> me ngā koeko<sup>20</sup>).</li> <li>te rārangi hāngai<sup>21</sup>, te rārangi whakarara<sup>22</sup> me te rārangi pūtahi<sup>23</sup></li> <li>te koki hāngai<sup>24</sup>.</li> </ul>	<p><sup>12</sup>unit of measurement</p> <p><sup>13</sup>approximate</p> <p><sup>14</sup>pace, stride</p> <p><sup>15</sup>reasonableness</p> <p><sup>16</sup>estimation</p> <p><sup>17</sup>geometric properties</p> <p><sup>18</sup>polyhedron</p> <p><sup>19</sup>prism</p> <p><sup>20</sup>pyramid</p> <p><sup>21</sup>perpendicular line</p> <p><sup>22</sup>parallel line</p> <p><sup>23</sup>intersecting line</p> <p><sup>24</sup>right angle</p>

## Te Reo Matatini o te Pāngarau

Hei tauira kupu		
<ul style="list-style-type: none"> <li>waeine</li> <li>tapatoru, tapawhā, taparima ...</li> <li>whakatau tata</li> <li>mataono rite</li> <li>tapatoru hāngai, tapatoru hikuwaru ...</li> <li>koki</li> <li>hāngai</li> </ul>	<ul style="list-style-type: none"> <li>akitu/kokonga</li> <li>koeko tapatoru, koeko tapawhā ...</li> <li>mata</li> <li>mita, mitarau, mitamano, manomita</li> <li>rūri</li> <li>pūtahi</li> </ul>	<ul style="list-style-type: none"> <li>tapa</li> <li>poro tapatoru, poro tapawhā ...</li> <li>rita, ritamano</li> <li>karamu, karamumano, manokaramu</li> <li>whakarara</li> </ul>
Hei tauira whakaahuahanga		
<ul style="list-style-type: none"> <li>mm, cm, m, km</li> </ul>	<ul style="list-style-type: none"> <li>L, mL</li> </ul>	<ul style="list-style-type: none"> <li>mg, g, kg</li> </ul>

## He Tauira Rapanga

### Te Ine me te Hanga 2a

#### Rapanga 6

Whakamahia tō rūri hei ine i ngā mea nei. Inea ki te mitamano (mm) pātata rawa. Tuhia ō inenga ki te tūtohi, engari me whakatau tata ngā inenga i te tuatahi.

Te mea hei ine	Te whakataunga tata	Te inenga
te roa o te pukapuka taki kupu a Ngata		
te whānui o te pukapuka taki kupu a Ngata		
te mātotoru o te pukapuka taki kupu a Ngata		
te roa o tō pene		
tō matikara		

Kia tika te whakamahi i te rūri hei whakatutuki inenga roa. Ko ngā whakatau tata e tohu ana i te mōhio ki te rahi o te mitarau (cm).

# WHANAKETANGA 2a

## Te Ine me te Hanga 2a

### Rapanga 7

**Rauemi:** He rūri mita.

E  $\frac{3}{2}$  mita te roa o te peke a Hineora. Tuhia he rārangi, ki te papa hei whakaatu i te roa o tana peke.

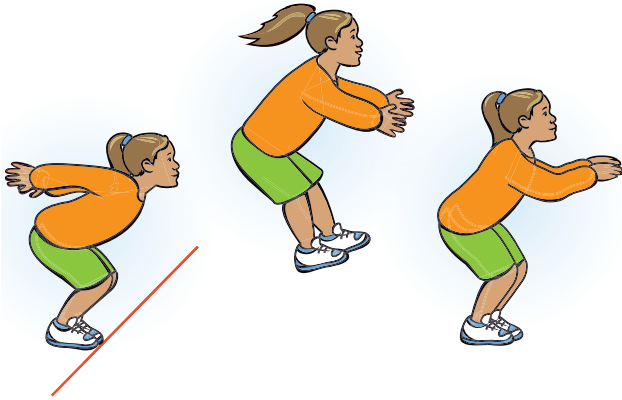

Kia tika te ine me te tuhi i te rārangi, mā te tatau i ngā haurua mita e toru, mā te tāpiri rānei i te haurua mita ki te kotahi mita.

### Rapanga 8

Whakamāramatia ngā āhuatanga hanga o tētahi taparau, ka tono ai i ngā ākonga kia tuhia te taparau, kia whakaingoa hoki. Hei tauira:

Kotahi te koki hāngai, e toru ngā tapa o tēnei āhua.



E whā ngā tapa o tēnei āhua, e rua ōna koki hāngai.

Kia tika te tuhi i ngā taparau me te whakaingoa anō hoki, hei whakaatu mā te ākonga i tōna mōhio ki ngā āhuatanga hanga nei: tapa, rārangi hāngai, rārangi whakarara, koki hāngai, kokonga/akitu.

## Te Ine me te Hanga 2a

### Rapanga 9

Tuhia ēnei inenga ki te taha o te mea e tika ana, me te tuhi hoki i te waeine tika:

2      10       $4\frac{1}{2}$       1

- te rōrahi o tētahi pākete
- te tāroaroa o tētahi tamaiti
- te tāroaroa o tētahi pakeke
- te roa o tētahi motukā.



Whakamāramatia he aha i pēnā ai ō whakaaro.

Kia tika te hoatu i ngā inenga me ngā waeine:

- 10 L (rita) te rōrahi o tētahi pākete
- 1 m (mita) te tāroaroa o tētahi tamaiti
- 2 m (mita) te tāroaroa o tētahi pakeke
- $4\frac{1}{2}$  m (mita) te roa o tētahi motukā.

Ko ngā whakamārama kia āhua pēnei:

- E mōhio ana ahau he āhua rite taku mārō ki te kotahi mita. E rua o ēnā ka pātata ki te tāroaroa o taku matua.
- Kei te takiwā o te kotahi mita taku tāroaroa.
- E whā, e rima rānei ngā hīkoitanga (whetoko) kia rite ki te roa o tētahi motukā. Ko te whā mita, te rima mita rānei tērā.
- E mōhio ana ahau ki te rahi o te ipu miraka e rua rita te rahi. E rima o ēnā ka uru ki te pākete, nō reira ko te 10 rita tērā.

## Te Wāhi, te Ahunga, me te Panoni

Ngā Whāinga		
Ka whakaoti rapanga te ākonga, ka whakamārama otinga, e whai wāhi mai ana:	He tauira ēnei o ngā āhuratanga me mātua mōhio te ākonga e tutuki ai tana whakaoti rapanga:	
<ul style="list-style-type: none"> <li>te tautohu ahunga<sup>25</sup> matua</li> <li>te whakaatu taunga<sup>26</sup> māmā ki te tukutuku<sup>27</sup></li> <li>te whakaata<sup>28</sup>, te neke, me te huri i tētahi āhua māmā.</li> </ul>	<ul style="list-style-type: none"> <li>ngā kupu whānui mō te ahunga me te taunga, (pēnei i ēnei: uta, tai, rahaki, tua, me ētahi noa atu)</li> <li>ngā ahunga matua o te kāpehu</li> <li>te hangarite<sup>29</sup> o tētahi āhua māmā.</li> </ul>	<sup>25</sup> direction <sup>26</sup> position <sup>27</sup> grid <sup>28</sup> reflection <sup>29</sup> symmetry

## Te Reo Matatini o te Pāngarau

Hei tauira kupu		
<ul style="list-style-type: none"> <li>hangarite</li> <li>neke</li> <li>pou</li> <li>whakarunga</li> <li>whakatematau</li> <li>rāwhiti, whakaterāwhiti</li> </ul>	<ul style="list-style-type: none"> <li>whakaata</li> <li>huri</li> <li>kapa</li> <li>whakararo</li> <li>raki/tokerau, whakateraki</li> <li>uru, whakateuru</li> </ul>	<ul style="list-style-type: none"> <li>kauhuri/huripoki</li> <li>whakarahi</li> <li>tukutuku</li> <li>whakatemauī</li> <li>tonga, whakatetonga</li> </ul>

## He Tauira Rapanga

Te Wāhi, te Ahunga, me te Panoni 2a

### Rapanga 10

Rauemi: He kāri e whakaatu ana i ētahi panoni. Hei tauira:

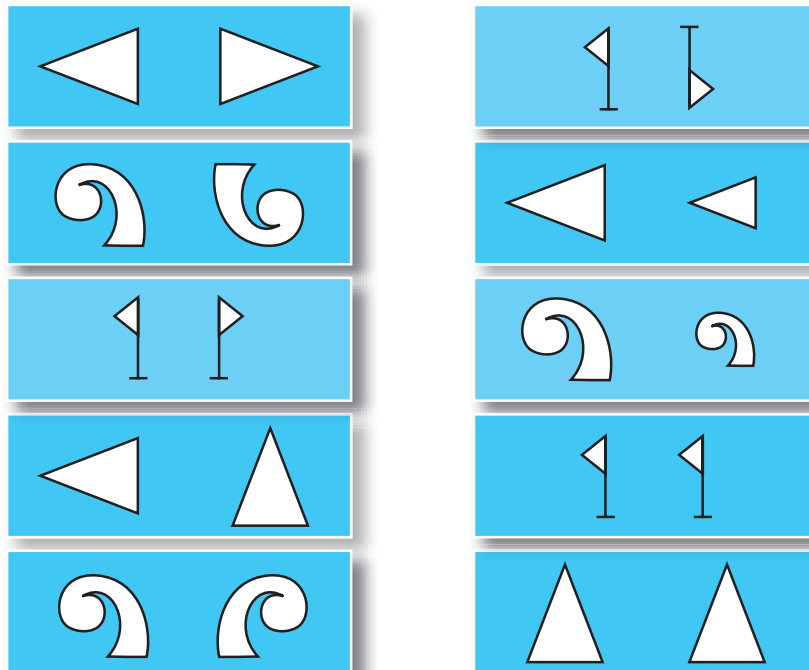

- Whakarōpūngia ngā kāri nei, ka whakamārama mai ai i ngā āhuratanga ake o ia rōpū.
- Whakamāramatia mai ka ahatia te āhua i te taha mauī o ia kāri kia puta ai te āhua i te taha matau.

Ka whakarōpūngia ngā kāri i runga i te āhua o te panoni, me te whakamārama anō i ngā panoni. Ka whakamahia ngā kupu motuhake e hāngai ana ki te panoni, pērā i te whakaata, te kauhuri, te huri, te neke, me te whakarahi, te whakaiti rānei.

Te Wāhi, te Ahunga, me te Panoni 2a

## Rapanga 11

**Rauemi:** He kāri tukutuku 3 x 3, he poro āhuetanga ake, he ārai.

Ka mahi takirua ngā ākonga, ka noho tauaro tētahi ki tētahi, me tētahi ārai ki waenganui, kia kore ai tētahi e kite i te papa tukutuku a tētahi. Ko tā tētahi, he whakatakoto i ētahi poro e whā ki ētahi wāhi o tana tukutuku, ā, ka whakamārama atu ki tana hoa i te wāhi noho o tēnā me tēnā o ngā poro me te āhua o te poro. Ko tā te hoa, he whai i ngā whakamārama me te whakatakoto i ngā poro e tika ana ki ngā wāhi o tana tukutuku e tika ana.

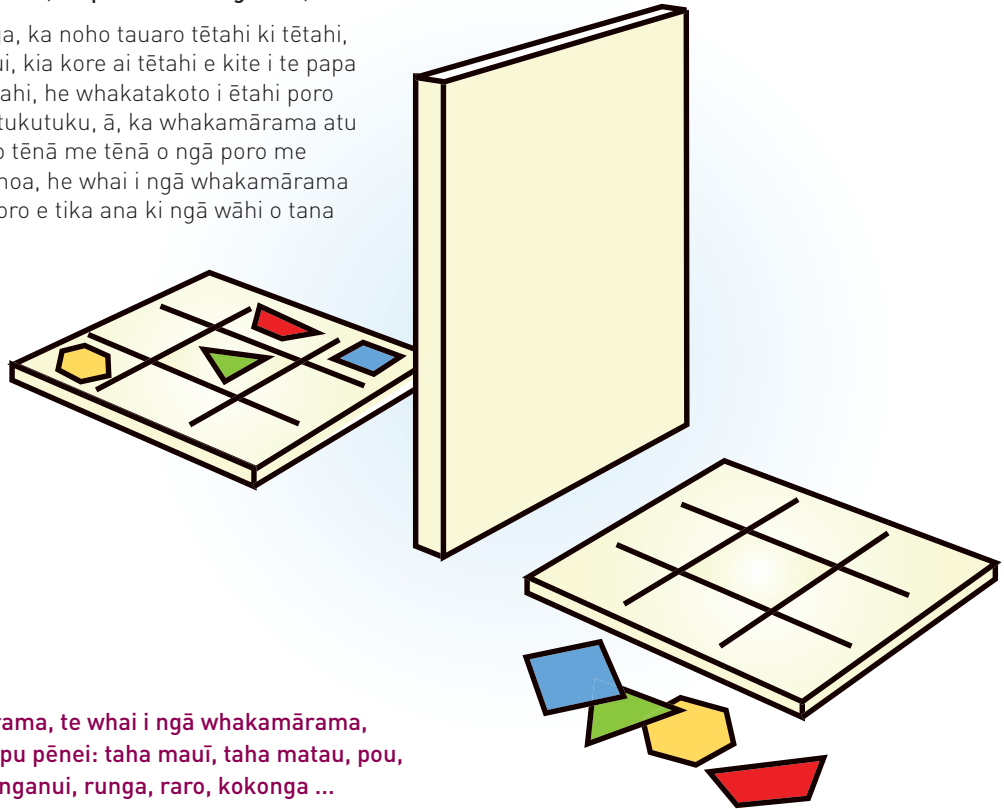

Kia tika te tuku whakamārama, te whai i ngā whakamārama, me te whakamahi i ngā kupu pēnei: taha mauī, taha matau, pou, kapa, tuatahi, tuarua, waenganui, runga, raro, kokonga ...

Te Wāhi, te Ahunga, me te Panoni 2a

## Rapanga 12

**Rauemi:** He pepa tukutuku e whakaatu ana i ngā pūwāhi A me E.

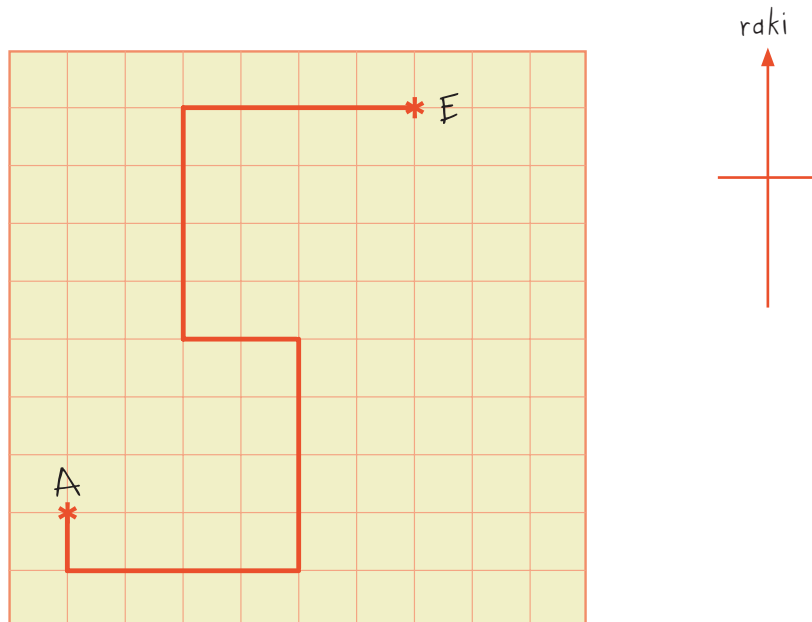

Ka tuhi te ākonga i tētahi huarahi mai i te pūwāhi A ki te pūwāhi E, kātahi ka whakamārama atu i taua huarahi ki tētahi hoa. Mā te hoa e whai haere ngā whakamārama, me te tuhi i taua huarahi ki tana tukutuku.

Kia tika te tuku whakamārama, te whai i ngā whakamārama, me te whakamahi i ngā kupu pēnei: raki, rāwhiti, tonga, uru, whakatemauī, whakatematau, whakarunga, whakararo ...

## Te Tauanga

Ngā Whāinga		
Ka whakaoti rapanga te ākonga, ka whakamārama otinga, e whai wāhi mai ana:	He tauira ēnei o ngā āhuratanga me mātua mōhio te ākonga e tutuki ai tana whakaoti rapanga:	
<ul style="list-style-type: none"> <li>te whakatakoto pātai māmā me te kohikohi <b>raraunga</b><sup>30</sup> e hāngai ana, hei whakautu i ngā pātai</li> <li>te hanga me te <b>whakamāori</b><sup>32</sup> <b>whakaari raraunga</b><sup>33</sup> e hāngai ana ki ngā raraunga i kohia.</li> </ul>	<ul style="list-style-type: none"> <li>te whakaatu raraunga ki te <b>tūtohi tatau</b><sup>31</sup></li> <li>te whakaputa kōrero mō ngā āhuratanga matua o tētahi huinga raraunga.</li> </ul>	<sup>30</sup> data <sup>31</sup> tally chart <sup>32</sup> interpret <sup>33</sup> data display

## Te Reo Matatini o te Pāngarau

Hei tauira kupu		
• raraunga	• whakaari raraunga	• tūtohi tatau
Hei tauira whakaahuhanga		
• tūtohi tatau	• kauwhata whakaahua	

## He Tauira Rapanga

### Te Tauanga 2a

### Rapanga 13

Tonoa ngā ākonga kia whakahaere i tētahi tūhuratanga tauanga mō tētahi kaupapa e whaitake ana ki te akomanga. Hei tauira, ko te whiriwhiri i te momo hua rākau hei whakatō mā te akomanga i tētahi mōra hou o te kura.

Kia hāngai tonu te whakatakoto i te pātai, te kohikohi me te whakaatu raraunga. Hei tauira, mā ia ākonga e whakamau rawhi ki tētahi rīpene hei tohu i te momo hua rākau e hiahia ana.

### Te Momo Hua Rākau E Hiahia Ana

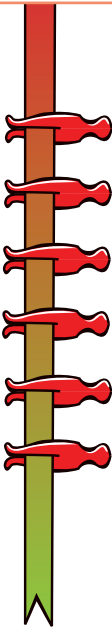
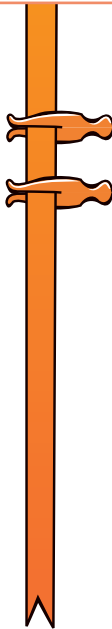
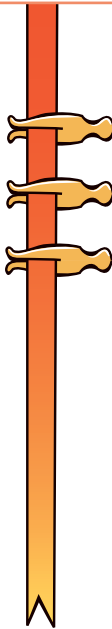
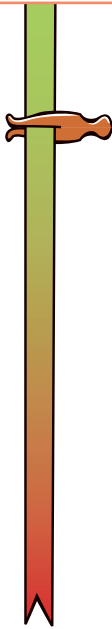
ped	āporo	ārani	pītiti	netarini
				

## Te Tūponotanga

Ngā Whāinga		
Ka whakaoti rapanga te ākonga, ka whakamārama otinga, e whai wāhi mai ana:	He tauira ēnei o ngā āhuatanga me mātua mōhio te ākonga e tutuki ai tana whakaoti rapanga:	
<ul style="list-style-type: none"> <li>te reo māmā hei whakaahua i te tūponotanga o tētahi putanga<sup>34</sup>.</li> </ul>	<ul style="list-style-type: none"> <li>te ōrite, te rerekē, te rangirua<sup>35</sup> rānei o ngā putanga o tētahi pāpono<sup>36</sup>.</li> </ul>	<sup>34</sup> outcome <sup>35</sup> uncertainty <sup>36</sup> event

## Te Reo Matatini o te Pāngarau

Hei tauira kupu		
<ul style="list-style-type: none"> <li>tūponotanga</li> <li>whakamātau</li> </ul>	<ul style="list-style-type: none"> <li>kāore e kore, ākene pea, tērā pea, e kore, kore rawa ...</li> </ul>	<ul style="list-style-type: none"> <li>matapae</li> </ul>

## He Tauira Rapanga

### Te Tūponotanga 2a

### Rapanga 14

**Rauemi:** Ētahi pūrere takahurihuri (pēnei i ngā mea e whakaahuangia ana ki raro iho nei), he kāri hei tuhi i ngā putanga o te pūrere takahurihuri.

Ka takahurihia te pūrere, ā, ka tuhia he "X" ki te kāri, hei tohu i te tae e tau ai te pūrere. Ko tēhea te tae tuatahi kia tekau ngā taunga a te pūrere takahurihuri?

- Tonoa te ākonga kia matapae i te tuatahi, kātahi ka whakamātau.
- Hoatu ētahi porowhita rerekē hei papa mō te pūrere takahurihuri, hei matapae, hei whakamātau mā te ākonga.

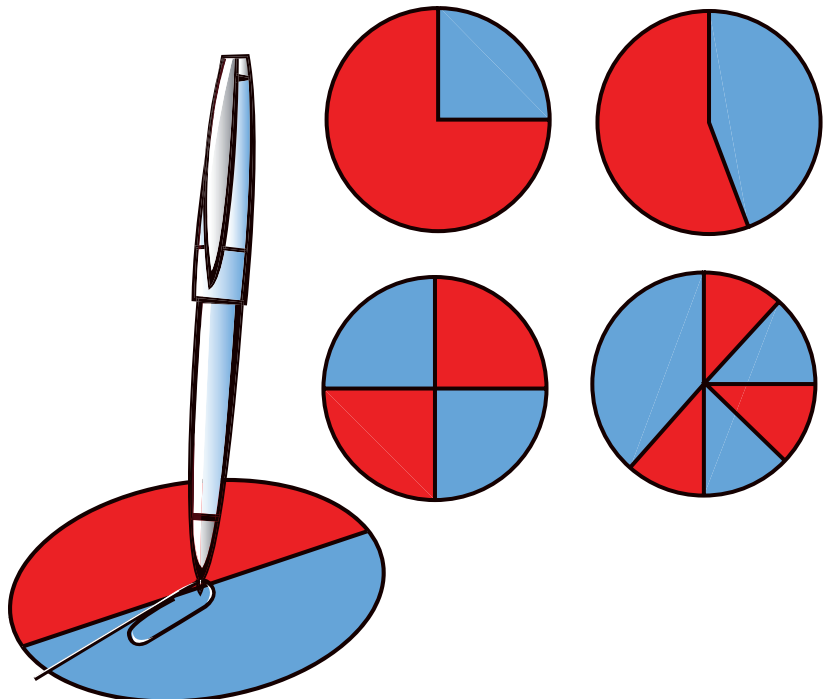
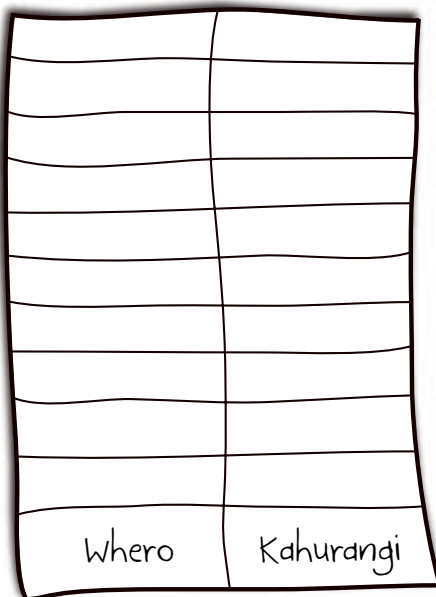

Ka matapae te ākonga i te tūponotanga o ia tae i runga anō i te hautanga o taua tae i te porowhita. Ka whakamārama hoki i tana matapae. Hei tauira:

- Kāore e kore ka wini te whero, nā te mea he tino rahi ake te wāhanga whero o te porowhita i te wāhanga kahurangi.
- Ākene pea ka wini te whero, ka wini te kahurangi rānei, nā te mea he ōrite te wāhanga whero me te wāhanga kahurangi o te porowhita.
- Tērā pea ka wini te whero, nā te mea he paku nui ake te wāhanga whero i te wāhanga kahurangi o te porowhita.

## Te Tau: Te Mātauranga Tau me ngā Rautaki Tau

(TPT) Kaupae 5

Ngā Whāinga		
Ka whakaoti rapanga te ākonga, ka whakamārama otinga, e whai wāhi mai ana:	He tauria ēnei o ngā āhuatanga me mātua mōhio te ākonga e tutuki ai tana whakaoti rapanga:	
<ul style="list-style-type: none"> <li>ngā rautaki wāwāhi tau<sup>1</sup> me te rautaki paheko kōaro<sup>2</sup> mō te tāpiritanga me te tangohanga</li> <li>ngā rautaki tāpiri tāruarua<sup>4</sup> mō te whakareatanga me te whakawehenga māmā, hei whiriwhiri hoki i te hautanga māmā o tētahi tau.</li> </ul>	<ul style="list-style-type: none"> <li>ngā tauoti mai i te 0 ki te 10 000 me te mātauranga uara tū<sup>3</sup> e hāngai ana</li> <li>ngā meka whakareatanga o te 2, te 5, me te 10 me ngā whakawehenga e whai pānga ana</li> <li>ngā kupu, ngā tohu, ngā whakaahuhanga<sup>5</sup>, me te tikanga o ngā haurua, ngā hatoru, ngā hauwhā, ngā haurima, ngā hauwaru, me ngā hautekau</li> <li>te raupapa hautau waetahi<sup>6</sup>.</li> </ul>	<ul style="list-style-type: none"> <li><sup>1</sup>part-whole strategy</li> <li><sup>2</sup>inverse operation strategy</li> <li><sup>3</sup>place value</li> <li><sup>4</sup>repeating addition</li> <li><sup>5</sup>representation</li> <li><sup>6</sup>unit fraction</li> </ul>

## Te Reo Matatini o te Pāngarau

Hei tauria kupu		
<ul style="list-style-type: none"> <li>wāwāhi</li> <li>paheko kōaro</li> </ul>	<ul style="list-style-type: none"> <li>meka whakareatanga</li> </ul>	<ul style="list-style-type: none"> <li>tāpiri tāruarua</li> </ul>
Hei tauria tohu		
<ul style="list-style-type: none"> <li>&lt;</li> </ul>	<ul style="list-style-type: none"> <li>&gt;</li> </ul>	
Hei tauria whakaahuhanga		
<ul style="list-style-type: none"> <li>rārangi tau wātea</li> </ul>		

## He Tauria Rapanga

### Te Tau 2e

### Rapanga 1

He toa a Huhana ki te tākaro māpere. E 87 ana māpere i te tīmatanga o te kēmu. I te mutunga, 105 ana māpere. E hia ngā māpere i wini i a ia i taua kēmu?

Kia tika te otinga (18), mā tētahi rautaki wāwāhi tau pēnei:

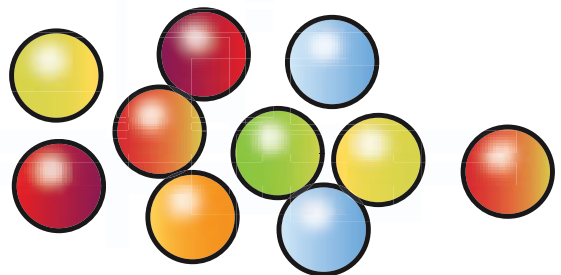

1

- Ka tīmata i te 87, tāpirihia te 20, ka 107. E 2 te rahinga kē atu i te tāpirihanga e tika ana, nō reira ka tangohia te 2 i te 20, ka 18.

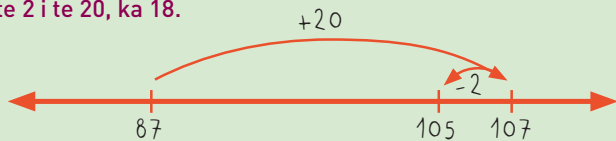

2

- Ka tīmata i te 105, ka tango i te 90, ka 15. E 3 te rahinga kē atu o te tangohanga e tika ana, nō reira ka tāpirihia te 3 ki te 15.

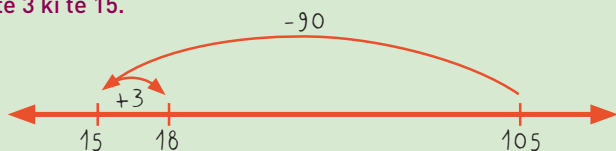

3

- Ka tīmata i te 87, ka tāpiri i te 3, ka 90. Tāpirihia te 15, ka 105. Hui katoa, ko te 18 tērā i tāpirihia.

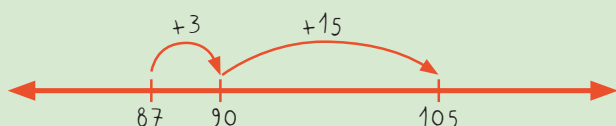

Te Tau 2e

## Rapanga 2

E \$50 te penapena moni a Hinewai i ia marama. E hia katoa ana moni penapena i te mutunga o te 6 marama?

Kia tika te otinga (\$300) mā tētahi rautaki wāwāhi tau pēnei:

- Ka whakamahia te meka whakareatanga  $5 \times 6$ .
- Ka whakareatia te \$100 ki te 6, kātahi ka whakahaurua.

Te Tau 2e

## Rapanga 3

E 40 ngā tamariki kei roto i te kapa haka o te kura. E toru hauwhā ( $\frac{3}{4}$ ) o ēnei he kōtiro. E hia katoa ngā kōtiro o te kapa haka?

Kia tika te otinga (30) mā tētahi rautaki wāwāhi tau pēnei:

- Ka whakahaurua i te haurua hei whiriwhiri i te hauwhā kotahi ( $\frac{1}{4}$ ), kātahi ka whakareatia ki te 3.

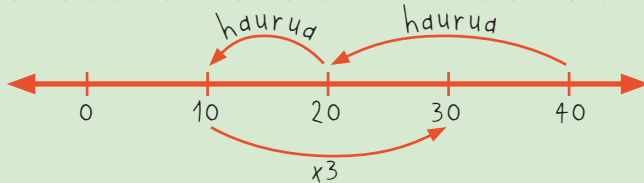

2

- Ka whakawehea te 40 ki te 4 hei whiriwhiri i te hauwhā kotahi ( $\frac{1}{4}$ ), kātahi ka whakareatia ki te 3.

Te Tau 2e

## Rapanga 4

E tākaro māpere ana a Hēmi. Ka ngaro i a ia te 23 o ana māpere, e 54 e toe mai ana. E hia ana māpere i te tīmatanga o te kēmu?

Kia tika te otinga (77), mā tētahi rautaki wāwāhi tau pēnei:

- Ka hurihia te tangohanga hei tāpiritanga, arā:  $\square - 23 = 54 \rightarrow 54 + 23 = \square$ . Ka wāwāhia te 23 ki te 20 me te 3, ā, ka tāpirihia ēnei wāhanga e rua.

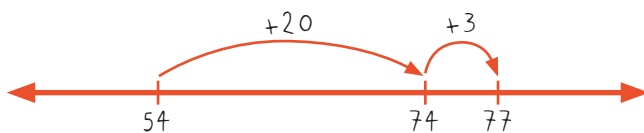

Te Tau 2e

## Rapanga 5

Tokotoru ngā tamariki e kai pīta ana. Kotahi hauono ( $\frac{1}{6}$ ) i kainga e Horowai, kotahi hauwhā ( $\frac{1}{4}$ ) i kainga e Mātahi, kotahi haurima ( $\frac{1}{5}$ ) i kainga e Tīmoti. Nā wai i kai te wehenga pīta nui rawa?

Kia tika te otinga (nā Mātahi – ko te hauwhā te hautanga nui rawa), i runga i te mōhio ki te rahi o ngā hautau waetahi, mā te tuhi rānei i tētahi pikitia pēnei i tēnei:

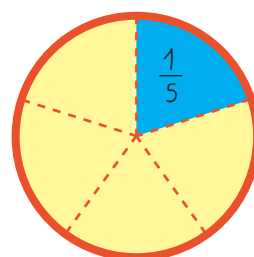
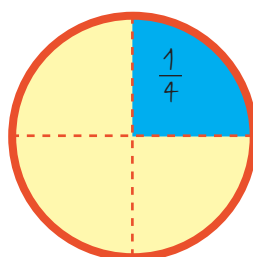
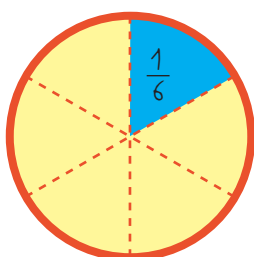



## Te Taura me te Pānga

Ngā Whāinga	
Ka whakaoti rapanga te ākonga, ka whakamārama otinga, e whai wāhi mai ana:	He taura ēnei o ngā āhuratanga me mātua mōhio te ākonga e tutuki ai tana whakaoti rapanga:
<ul style="list-style-type: none"> <li>te whiriwhiri me te whakamahi i te ture o tētahi taura māmā.</li> </ul>	<ul style="list-style-type: none"> <li>te whakamahi tohu hei whakaatu i te ture o tētahi taura.</li> </ul>

## Te Reo Matatini o te Pāngarau

Hei taura kupu
<ul style="list-style-type: none"> <li>ture</li> </ul>

## He Taura Rapanga

### Te Taura me te Pānga 2e

#### Rapanga 6

Ko te 3 te tau tīmatanga o tētahi taura raupapa, koia nei tōna ture: whakareatia te tau i mua ki te 2, ka tango ai i te 1.

Tuhia kia 6 ngā tau o tēnei raupapa.

Whakamāramatia mai tō mahi hei whiriwhiri i tētahi o ngā tau.

Kia tika te tuhi i ngā tau e 6 o te raupapa, arā, {3, 5, 9, 17, 33, 65}.

Kia tika hoki te whakamārama i te whiriwhiringa o tētahi tau. Hei taura, ka whakareatia te 17 ki te 2, ka 34, kātahi ka tangohia te 1, ka 33.

### Te Taura me te Pānga 2e

#### Rapanga 7

He hipi kei roto i te pātiki a Kaipāmu Rereahu.

Me pēhea te whiriwhiri i te maha o ngā waewae o ngā hipi?

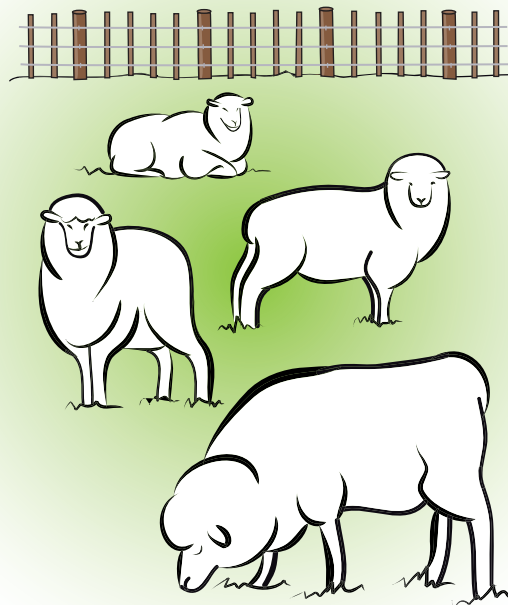

Kia tika te whakamārama, ka whakareatia te maha o ngā hipi ki te 4 nā te mea e whā ngā waewae o ia hipi. He pai hoki te whakaatu i te pānga ki te tūtohi, me te tuhi ā-tohu i te ture o te pānga.

ngā hipi	1	2	3	4	$\times 4$ ...
ngā waewae	4	8	12	16	...

## Te Ine me te Hanga

Ngā Whāinga		
Ka whakaoti rapanga te ākonga, ka whakamārama otinga, e whai wāhi mai ana:	He tauira ēnei o ngā āhuatanga me mātua mōhio te ākonga e tutuki ai tana whakaoti rapanga:	
<ul style="list-style-type: none"> <li>te kōwhiri i ngā waeine<sup>7</sup> e hāngai ana ki te horopaki me te tōtika anō o te inenga e whaitake ana</li> <li>te tuhi hoahoa me te hanga tauira o ngā āhua ahu-<sup>2</sup> me ngā āhua ahu-<sup>3</sup>.</li> </ul>	<ul style="list-style-type: none"> <li>te whakamahi i te rūri, te tāporowhita<sup>8</sup>, me te koki hāngai<sup>9</sup>, hei ine, hei tuhi āhua.</li> </ul>	<p><sup>7</sup>unit of measurement</p> <p><sup>8</sup>compass</p> <p><sup>9</sup>right angle</p> <p><sup>10</sup>2-dimensional shape</p>

## Te Reo Matatini o te Pāngarau

Hei tauira kupu		
<ul style="list-style-type: none"> <li>waeine</li> <li>mata</li> <li>tāporowhita</li> <li>hoahoa</li> <li>āhua ahu-<sup>3</sup></li> <li>tapahanga</li> </ul>	<ul style="list-style-type: none"> <li>āhua ahu-<sup>2</sup></li> <li>koki hāngai</li> <li>mataono rite</li> <li>poro tapawhā hāngai</li> <li>poro tapawhā rite</li> <li>poro tapatoru</li> </ul>	<ul style="list-style-type: none"> <li>rango, koeko</li> <li>koeko tapawhā rite</li> <li>koeko tapatoru</li> <li>koeko tapawhā hāngai</li> </ul>

## He Tauira Rapanga

### Te Ine me te Hanga 2e

### Rapanga 8

Kua tapahia tēnei āhua. He tapawhā rite te āhua ka puta i te tapahanga.

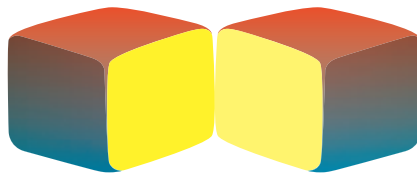
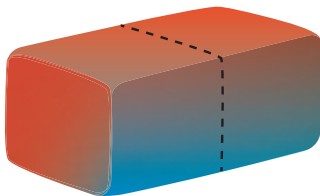

Te āhua ka puta i te tapahanga

Titiro ki ngā āhua e whai ake nei. Ko te rārangi iraira e whakaatu ana i te wāhi ka tapahia ngā āhua. Tuhia te āhua ka puta i te tapahanga.

1.

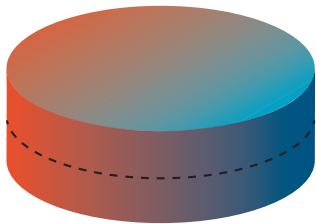

2.

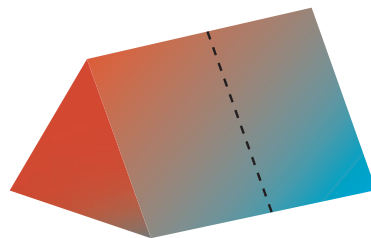

3.

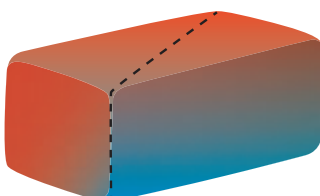

4.

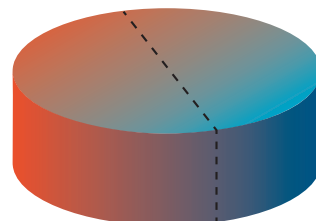

Kia tika te tuhi i te āhua o ngā tapahanga, te whakamahi i te rūri hei tuhi rārangi torotika, me te whakamahi tāporowhita hei tuhi porowhita.

## Te Ine me te Hanga 2e

### Rapanga 9

E whakaaturia ana ki te whakaahua nei te tāroaroa o ētahi ākonga tokowhā. Kotahi anake te tāroaroa e tika ana.

1. Ko ēhea ngā tāroaroa e hē ana?
2. Whakamāramatia mai he aha, ki ō whakaaro, e hē ana?

Kia tika te tautohu i ngā tāroaroa e hē ana me te hāngai anō o ngā whakamārama. Hei tauria:

- E hē ana te tāroaroa o Hone. He roa atu te 139 m i tētahi papa tākaro whutupōro. E hē ana te waeine. Ākene pea ko te 139 cm te tāroaroa e tika ana. Kua taka rānei te ira, arā, ko te 1.39 m tōna tāroaroa.
- Kāore e tika ana te tāroaroa o Keita. E rite ana te 185 cm ki te tāroaroa o tētahi pakeke, engari he poto ake ia i te whaea e tū ana i te taha.
- E hē ana te tāroaroa o Hera. He tino poto te 142 mm, he rite pea ki te whānui o tētahi pukapuka. Ko te 142 cm, te 1.42 m rānei te tāroaroa tika.

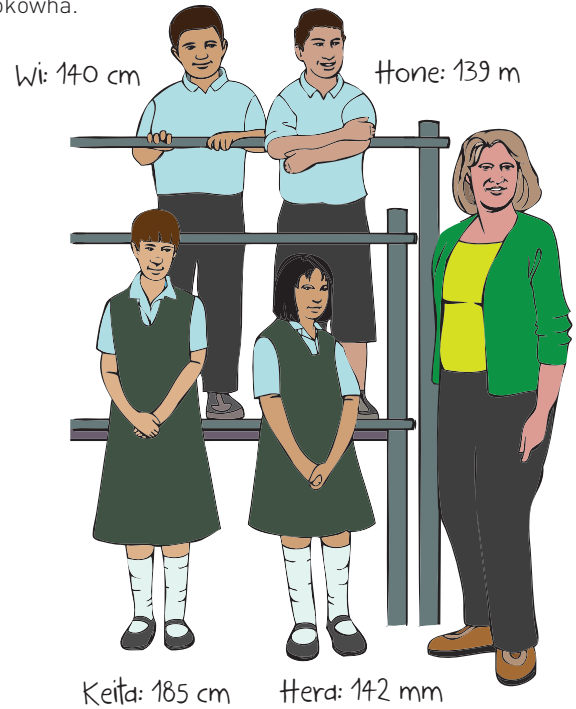

## Te Ine me te Hanga 2e

### Rapanga 10

**Rauemi:** He taura ine tīhaehae, he pukapuka, he rīpene, he kete.

Whakamahia te taura ine tīhaehae hei ine i ēnei mea:

- te whānui, te roa, me te mātotoru o te pukapuka
- te roa o te rīpene
- te whānui me te hōhonu o te kete.

Kia tika te whakamahi i te taura ine tīhaehae. Arā, ka tīmata pea i te 7, i te 10 rānei, ā, ka tangohia te 7 (te 10 rānei) i te inenga.

Ka whakaaturia te waeine e tika ana.

Kia tōtika te inenga ki te mitamano (mm) e pātata ana mō te whānui, te roa, me te mātotoru o te pukapuka, me te roa o te rīpene.

Kia tōtika te inenga ki te mitarau (cm) e pātata ana mō te whānui me te hōhonu o te kete.



## Te Wāhi, te Ahunga, me te Panoni

Ngā Whāinga		
Ka whakaoti rapanga te ākonga, ka whakamārama otinga, e whai wāhi mai ana:	He tauira ēnei o ngā āhuratanga me mātua mōhio te ākonga e tutuki ai tana whakaoti rapanga:	
<ul style="list-style-type: none"> <li>te whakaatu ahunga, taunga hoki ki te mahere māmā, pērā i ngā mahere o ngā wāhi e mōhiotia ana</li> <li>te whai me te hoatu tohutohu huarahi</li> <li>te tautohu i ngā āhuratanga ka noho pūmau<sup>12</sup>, me ngā āhuratanga ka rerekē i tētahi panoni<sup>13</sup>.</li> </ul>	<ul style="list-style-type: none"> <li>ngā taunga me ngā ahunga o ngā āhuratanga kōhure<sup>11</sup> o tōna wāhi noho, pēnei i te maunga, te awa, te marae, te kura, me ētahi noa atu.</li> </ul>	<p><sup>11</sup>distinctive features</p> <p><sup>12</sup>invariant</p> <p><sup>13</sup>transformation</p>

## Te Reo Matatini o te Pāngarau

Hei tauira kupu		
<ul style="list-style-type: none"> <li>mahere</li> <li>raki</li> <li>uru</li> <li>taunga</li> </ul>	<ul style="list-style-type: none"> <li>rāwhiti</li> <li>whakaatanga</li> <li>ahunga</li> <li>tonga</li> </ul>	<ul style="list-style-type: none"> <li>whakarahinga</li> <li>hurihanga</li> <li>nekenga</li> </ul>
Hei tauira whakaahuhanga		
<ul style="list-style-type: none"> <li>mahere māmā</li> </ul>	<ul style="list-style-type: none"> <li>tukutuku</li> </ul>	

## He Tauira Rapanga

### Te Wāhi, te Ahunga, me te Panoni 2e

#### Rapanga 11

**Rauemi:** He mahere o te kura.

Tonoa te ākonga kia whakaatu i ngā ahunga matua ki te mahere o te kura, arā, ko te raki, te rāwhiti, te uru, me te tonga. Tukuna he pātai mō te ahunga, pēnei i ēnei:

- Mēnā kei te tū koe ki waho i te akomanga, ā, e aro ana koe ki te rāwhiti, he aha kei tō taha mauī?
- Mai i te tomokanga matua o te kura, he aha te ahunga ki tō tātou akomanga?
- He aha kei te taha uru o te tomokanga matua o te kura?
- Mai i te kura, he aha te ahunga ki te maunga/awa/roto/marae?

**Kia tika te whakaatu i ngā ahunga matua ki te mahere me te whakautu i ngā pātai.**

## Te Wāhi, te Ahunga, me te Panoni 2e

### Rapanga 12

**Rauemi:** He mahere huarahi o te tāone (tētahi takiwā o te tāone mēnā he tāone nui).

I a koe e tū ana ki waho i te poutāpeta, ka tono mai tētahi tauhou mō ngā tohutohu kia tae atu ia ki te teihana tereina. He aha ō tohutohu ki a ia?

**Kia mārāma ngā tohutohu, me te whakamahi anō i ngā kupu ahunga e hāngai ana.**



## Te Wāhi, te Ahunga, me te Panoni 2e

### Rapanga 13

**Rauemi:** He pikitia e whakaatu ana i ētahi panoni.

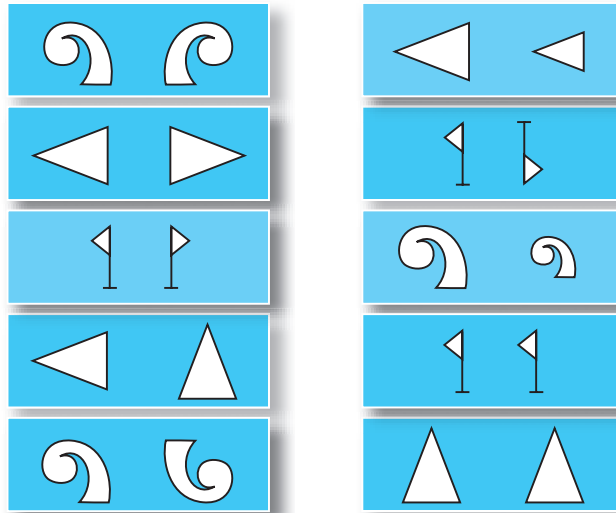

He aha ngā panoni e whakaaturia ana i ēnei pikitia?

Tohua mai tētahi pikitia e whakaatu ana i te whakaatanga.

- He aha ngā āhuatanga ōrite o ngā tapatoru/koru/pouhaki e rua i te pikitia?
- He aha ngā āhuatanga rerekē o ngā tapatoru/koru/pouhaki e rua i te pikitia?

Tohua mai tētahi pikitia e whakaatu ana i te whakarāhinga.

- He aha ngā āhuatanga ōrite o ngā tapatoru/koru/pouhaki e rua i te pikitia?
- He aha ngā āhuatanga rerekē o ngā tapatoru/koru/pouhaki e rua i te pikitia?

Tohua mai tētahi pikitia e whakaatu ana i te hurihanga.

- He aha ngā āhuatanga ōrite o ngā tapatoru/koru/pouhaki e rua i te pikitia?
- He aha ngā āhuatanga rerekē o ngā tapatoru/koru/pouhaki e rua i te pikitia?

**Kia tika te tautohu i ngā panoni. Kia tika hoki te whakamārāma i ngā āhuatanga ōrite me ngā āhuatanga rerekē o ia panoni, pērā i te rahi, te ahunga, te rahi o ngā koki, me te hanga.**

## Te Tauanga

Ngā Whāinga		
Ka whakaoti rapanga te ākonga, ka whakamārama otinga, e whai wāhi mai ana:	He tauira ēnei o ngā āhuratanga me mātua mōhio te ākonga e tutuki ai tana whakaoti rapanga:	
<ul style="list-style-type: none"> <li>te raraunga whakarōpū<sup>14</sup> me te raraunga motumotu<sup>15</sup></li> <li>te whakaputa kōrero mō ngā whakakitenga o tētahi tūhuratanga tauanga<sup>18</sup>.</li> </ul>	<ul style="list-style-type: none"> <li>te whakaatu raraunga ki te kauwhata pou<sup>16</sup> māmā me te kauwhata ira<sup>17</sup></li> <li>ngā tikanga matatika<sup>19</sup> e hāngai ana, (pērā i ngā momo pātai e tika ana kia kore ai te kaiwhakautu e mamae, e whakaitia rānei).</li> </ul>	<p><sup>14</sup>category data</p> <p><sup>15</sup>discrete data</p> <p><sup>16</sup>bar graph</p> <p><sup>17</sup>dot graph</p> <p><sup>18</sup>statistical investigation</p> <p><sup>19</sup>ethical conventions</p>

## Te Reo Matatini o te Pāngarau

Hei tauira kupu		
<ul style="list-style-type: none"> <li>kauwhata pou</li> <li>tuaka pou</li> </ul>	<ul style="list-style-type: none"> <li>kauwhata ira</li> <li>raraunga</li> </ul>	<ul style="list-style-type: none"> <li>tuaka pae</li> </ul>
Hei tauira whakaahuhanga		
<ul style="list-style-type: none"> <li>kauwhata pou</li> </ul>	<ul style="list-style-type: none"> <li>kauwhata ira</li> </ul>	

## He Tauira Rapanga

### Te Tauanga 2e

### Rapanga 14

**Rauemi:** He kauwhata pou māmā pēnei i tēnei, e whakaatu ana i ētahi raraunga motumotu:

Ka whakaputa kōrero te ākonga mō te kauwhata pou, ka whakautu pātai rānei.

Kia tika ngā kōrero, ngā whakautu pātai rānei mō te kauwhata. Hei tauira:

- Ko te 105 te whiwhinga nui rawa a Tihirau i roto i ana kēmu e waru.
- E hia ngā omanga a Tihirau i tana kēmu tuarima? (10)
- E hia te maha ake o ngā omanga i tana kēmu tuarua, tērā i tana kēmu tuaono? (75)
- Pēhea nei te pai o Tihirau ki te patu omanga kirikiti? (I ētahi kēmu he pai, i ētahi kēmu kāore i te pērā rawa te pai, arā, ka piki, ka heke te maha o ana omanga.)
- He aha pea ngā take i pērā ai te patu omanga a Tihirau? (I ētahi kēmu pea he autaiā te epa pōro a te hoariri, i ētahi kēmu he māmā noa iho ngā epa.)

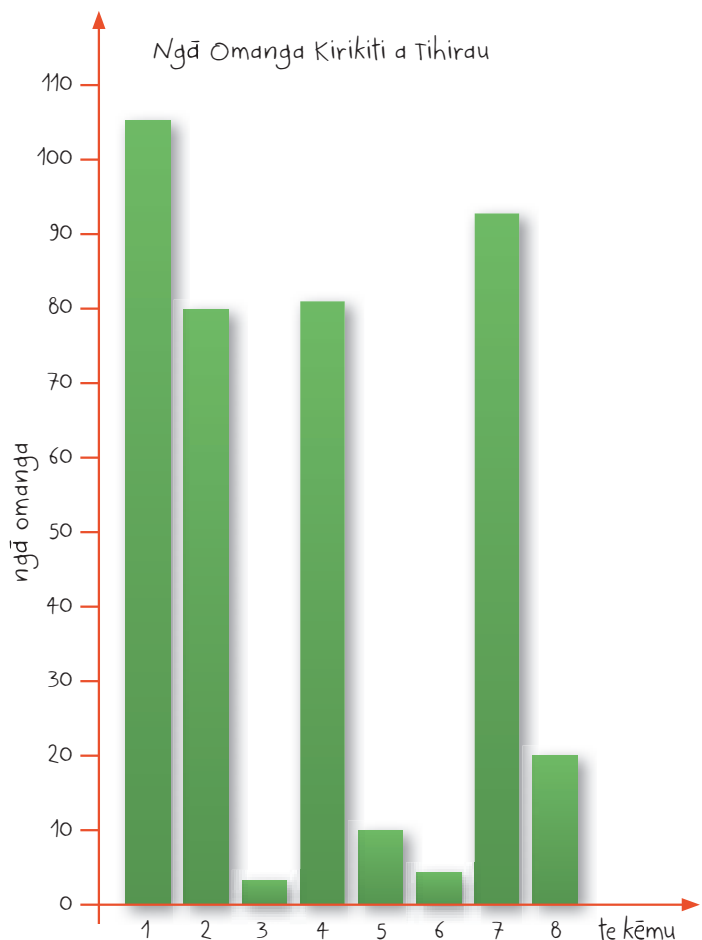

## Te Tauanga 2e

### Rapanga 15

**Rauemi:** He pepa tukutuku, he rorohiko rānei (me tētahi hōtaka ripanga).

Ka whakahaere tūhuratanga kia kitea ai te tere urupare a ngā ākonga ki te hopu rūri, pēnei i te pikitia nei. Ka puritia te rūri e tētahi ākonga ki runga ake i te ringaringa o tana hoa. Ka tukuna te rūri kia taka, ā, ka tuhia te inenga o te wāhi i te rūri i hopukina ai. Ka whakaaturia ngā raraunga ki tētahi kauwhata pou, ka whakaputa kōrero ai, ka whakautu pātai rānei mō te kauwhata.

**Kia tika te whakahaere i ngā inenga.**

**Kia tika te whakaatu i ngā raraunga ki te kauwhata pou.**

**Kia tika te whakaputa whakaaro, whakautu pātai rānei mō te kauwhata.**

**Hei tauira:**

- Ko tēhea te inenga o te tokomaha o ngā ākonga?
- Ko te 8 cm te inenga tere rawa atu.
- Kei waenganui i te 8 cm me te 24 cm ngā inenga katoa.

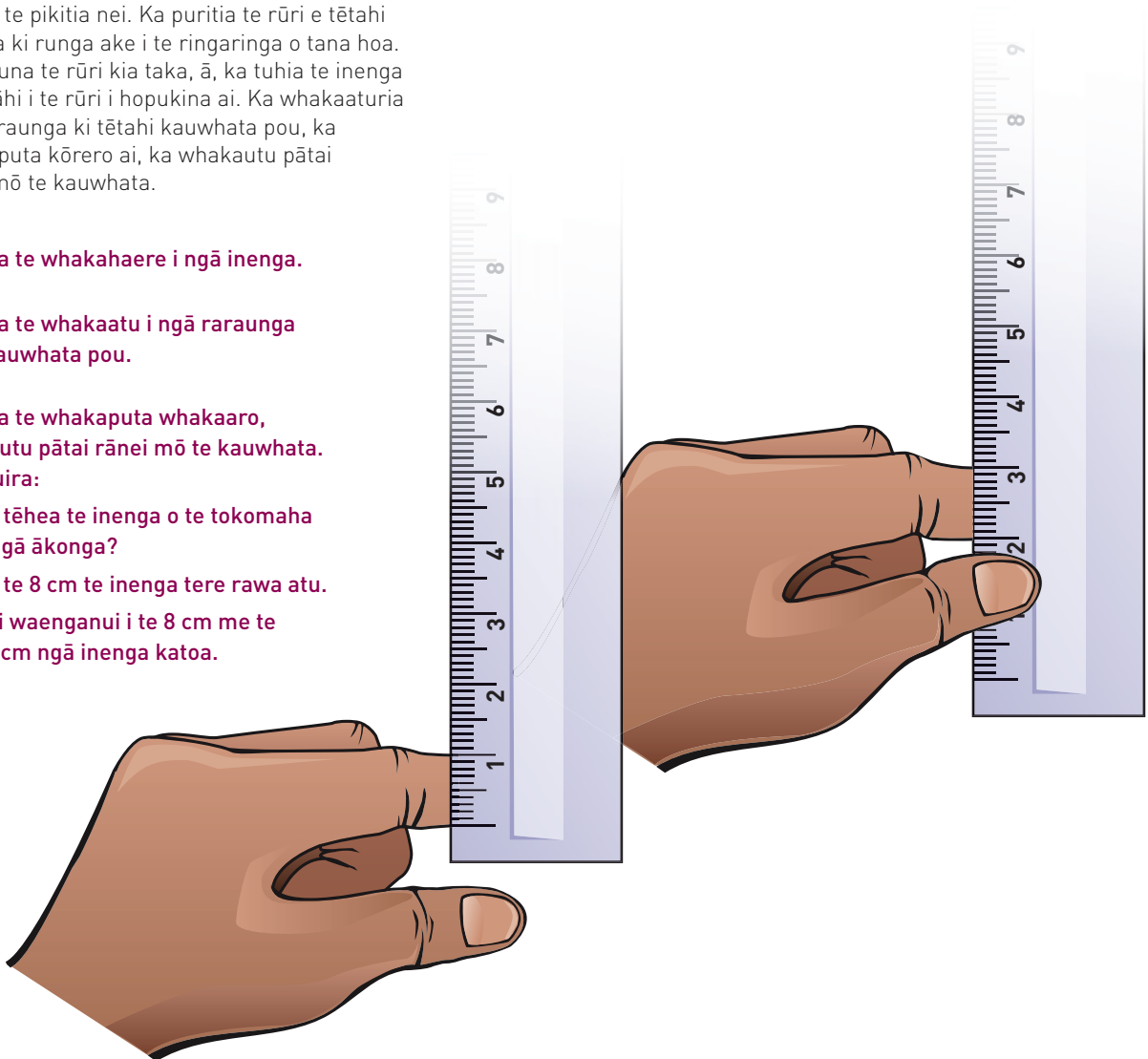

## Te Tūponotanga

Ngā Whāinga		
Ka whakaoti rapanga te ākonga, ka whakamārama otinga, e whai wāhi mai ana:	He tauira ēnei o ngā āhuetanga me mātua mōhio te ākonga e tutuki ai tana whakaoti rapanga:	
<ul style="list-style-type: none"> <li>te whakaatu tūponotanga ki tētahi āwhata<sup>20</sup></li> <li>te whakamāori<sup>22</sup> whakaari raraunga māmā hei matapae i te putanga o tētahi pāpono tūponotanga<sup>23</sup>.</li> </ul>	<ul style="list-style-type: none"> <li>te whakaatu putanga<sup>21</sup> ki tētahi whakaari raraunga māmā (pērā i te kauwhata ira, te kauwhata whakaahua, me te kauwhata pou).</li> </ul>	<sup>20</sup> scale <sup>21</sup> outcome <sup>22</sup> interpret <sup>23</sup> probability event

## Te Reo Matatini o te Pāngarau

Hei tauira kupu		
<ul style="list-style-type: none"> <li>tūponotanga</li> <li>putanga</li> </ul>	<ul style="list-style-type: none"> <li>āwhata</li> </ul>	<ul style="list-style-type: none"> <li>pāpono</li> </ul>
Hei tauira whakaahuhanga		
<ul style="list-style-type: none"> <li>kauwhata ira</li> </ul>	<ul style="list-style-type: none"> <li>kauwhata pou</li> </ul>	<ul style="list-style-type: none"> <li>tūtohi</li> </ul>

## He Tauira Rapanga

### Te Tūponotanga 2e

### Rapanga 16

**Rauemi:** He pūrere takahurihuri.

E rua ngā tae o te papa o te pūrere takahurihuri, ko te whero me te kōwhai.

E whakaaturia ana ki te kauwhata pou ngā putanga o ētahi takahurihanga 20.

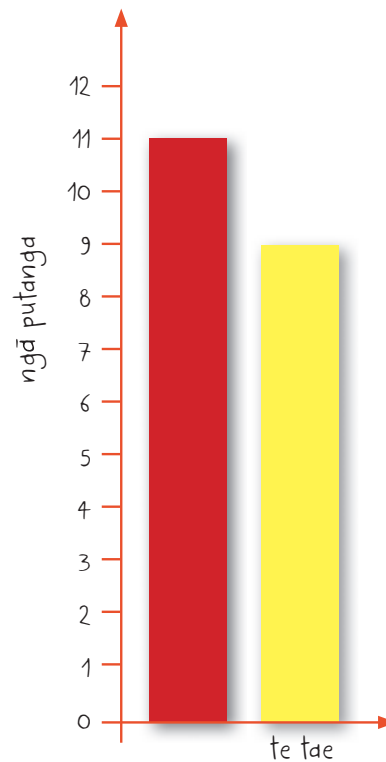
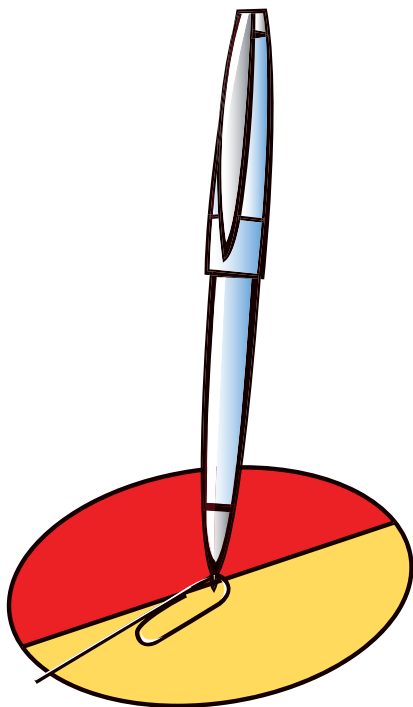



Tuhia te āhua o te papa o te pūrere takahurihuri e hāngai ana ki ēnei kauwhata pou, ka whakamārama ai:

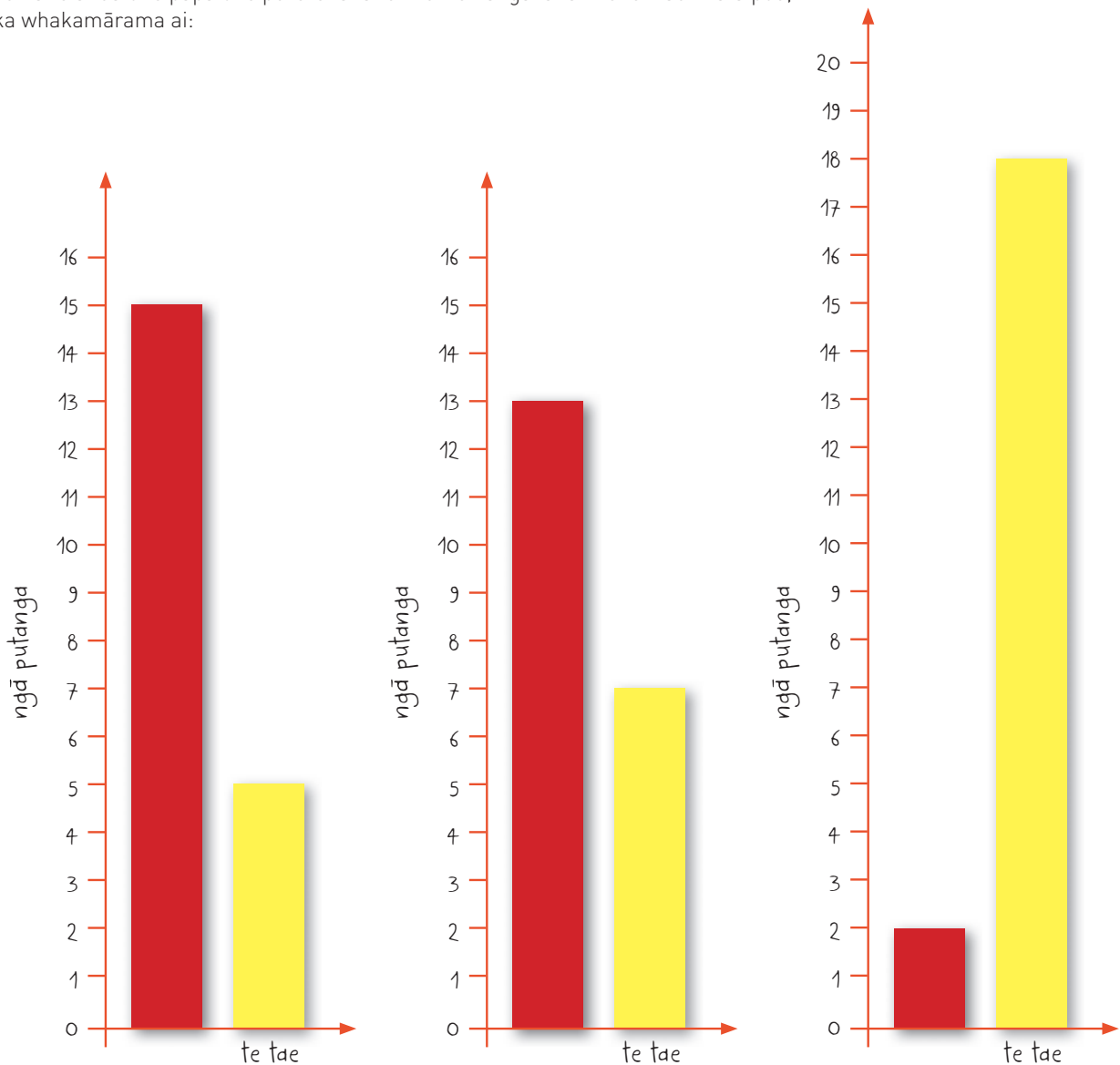

Kia mōhio te ākongā ki te whakamāori i te kauwhata pou me te tūponotanga o ia putanga e whakaaturia ana. Hei tauira, he tino nui ake te puta o te whero i te kauwhata tuatahi, nō reira he nui te tūponotanga he rahi ake te wāhanga whero o te papa porowhita o te pūrere takahurihuri.

Kia mōhio te ākongā ki te whakamāori i ngā kauwhata pou, me te hāngai ki te tūponotanga matapae o ia putanga. Hei tauira whakamārama:

- He āhua nui ake te puta o te whero i te kauwhata tuatahi, nō reira he āhua nui te tūponotanga he rahi ake te wāhanga whero o te papa porowhita o te pūrere takahurihuri. He pēnei pea te āhua:
- He paku nui ake te puta o te whero i te kauwhata tuarua, nō reira he paku nui ake pea te wāhanga whero o te papa o te pūrere takahurihuri. He pēnei pea te āhua:
- He tino nui ake te puta o te kōwhai i te kauwhata tuatoru, nō reira he tino nui te tūponotanga he tino rahi kē ake te wāhanga kōwhai o te papa porowhita o te pūrere takahurihuri. He pēnei pea:



## Te Tau: Te Mātauranga Tau me ngā Rautaki Tau

(TPT) Kaupae 6

Ngā Whāinga		
Ka whakaoti rapanga te ākonga, ka whakamārama otinga, e whai wāhi mai ana:	He tauira ēnei o ngā āhuatanga me mātua mōhio te ākonga e tutuki ai tana whakaoti rapanga:	
<ul style="list-style-type: none"> <li>ngā rautaki wāwāhi tau whānui mō te tāpiritanga me te tangohanga</li> <li>ngā rautaki whakareā<sup>2</sup> māmā mō te whakareatanga, te whakawehenga, me te whiriwhiri hautanga māmā o tētahi tauoti.</li> </ul>	<ul style="list-style-type: none"> <li>ngā tauoti mai i te 0 ki te 100 000, mō te mātauranga uara tū<sup>1</sup> e hāngai ana</li> <li>ngā hautau noa me nga hautanga ā-ira (kia kotahi te mati ā-ira<sup>3</sup>)</li> <li>ngā meka whakareatanga ki te 10 x 10, me ngā whakawehenga e whai pānga ana</li> <li>te raupapa hautau māmā</li> <li>ngā momo whakaahuahanga<sup>4</sup> hautanga ā-ira, me te hononga ki ngā hautau noa.</li> </ul>	<p><sup>1</sup>place value</p> <p><sup>2</sup>multiplicative strategy</p> <p><sup>3</sup>decimal places</p> <p><sup>4</sup>representations</p>

## Te Reo Matatini o te Pāngarau

Hei tauira kupu		
<ul style="list-style-type: none"> <li>huatango</li> <li>mati</li> <li>rautaki</li> <li>tau ā-ira</li> </ul>	<ul style="list-style-type: none"> <li>tau māmā</li> <li>mati ā-ira</li> <li>rahinga ake</li> </ul>	<ul style="list-style-type: none"> <li>wāwāhi uara tū</li> <li>mati-rau, mati-tekau, mati-tahi, mati-hautekau ...</li> <li>whakareatanga ake</li> </ul>
Hei tauira whakaahuahanga		
<ul style="list-style-type: none"> <li>he rārangi tau</li> <li>he pakitara hautau</li> </ul>	<ul style="list-style-type: none"> <li>he rārangi tau matarua</li> <li>he papa-hautekau</li> </ul>	<ul style="list-style-type: none"> <li>he porowhita hautau</li> </ul>

## He Tauira Rapanga

Te Tau 3a

### Rapanga 1

E \$363 kei roto i te pūtea pēke a Himiona. Ka tangohia e ia te \$37 hei hoko i tētahi taonga. E hia tāra e toe ana i tana pūtea?

Kia tika te otinga (\$326) me te whakamārama i tētahi rautaki wāwāhi tau pēnei i te tāpiritanga ōrite:

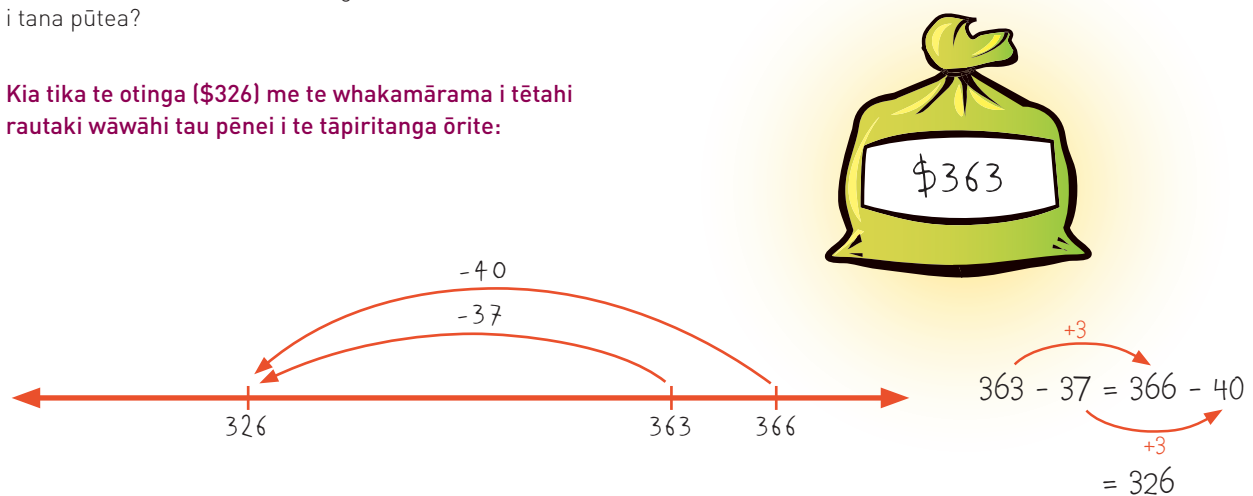

Ka tāpiria te 3 ki te 363 me te 37. E toru te rahinga ake o te tau tīmatanga, engari e toru hoki te rahinga ake o te tau tango. Nō reira ka pūmau tonu te rahi o te huatango. He tau māmā te 40, he māmā ake te tango i te 40 tērā i te tango i te 37.

# WHANAKETANGA 3a

Te Tau 3a

## Rapanga 2

\$14 te utu mō tētahi tīkiti konohete. E hia te utu mō ngā tīkiti e 4?



Kia tika te otinga (\$56), me te whakamārama i tētahi rautaki whakarea māmā. Hei taurira:

1

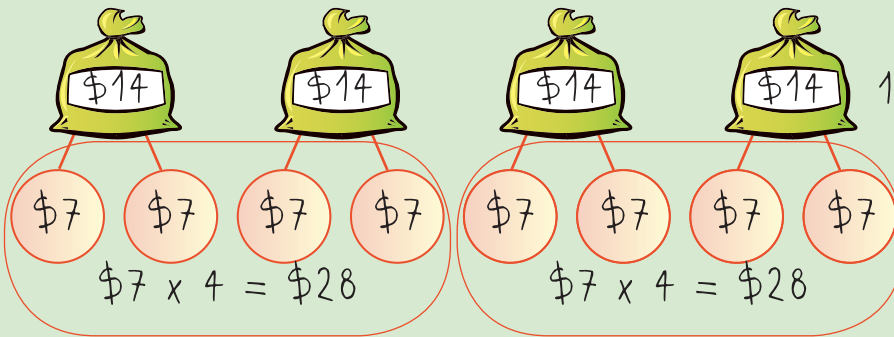

$$\begin{aligned} 14 \times 4 &= (7 \times 4) + (7 \times 4) \\ &= 28 + 28 \\ &= 56 \end{aligned}$$

Ka hauruatia te \$14, ka \$7. E 4 ngā \$7, ka \$28. Tāpirihia te \$28 me te \$28, ka \$56.

2

$$\begin{array}{r} \$14 \longrightarrow \$10 + \$4 \\ \times 4 \qquad \quad \times 4 \quad \times 4 \\ \hline \qquad \quad \$40 + \$16 \longrightarrow \$56 \end{array}$$

Ka wāwāhia te \$14 ki te \$10 me te \$4. Ka whakareatia te \$10 ki te 4, ka \$40. Ka whakareatia te \$4 ki te 4, ka \$16. Hui katoa te \$40 me te \$16, ka \$56.

Te Tau 3a

## Rapanga 3

E \$76 te pūtea a Mereana. Ka pau i a ia te hauwhā kotahi ( $\frac{1}{4}$ ) o tana pūtea ki te hoko perehana mā tana hoa. E hia tāra te utu o te perehana?

$$\frac{1}{4} \text{ o te } \$76$$

Kia tika te otinga (\$19), me te whakamārama i tētahi rautaki whakarea māmā. Hei taurira:



Wāwāhia te 76 ki te 60 me te 16.  
Hauruatia te 60, hauruatia te 16.  
Hauruatia anō te 30 me te 8.  
Hui katoa te 15 me te 4, ka 19.

Ka wāwāhia te 76 ki te 60 me te 16 nā te mea he tau māmā ērā. Ka hauruatia te haurua o ēnei tau māmā ( $\frac{1}{2}$  o te  $\frac{1}{2}$  o te 60 = 15,  $\frac{1}{2}$  o te  $\frac{1}{2}$  o te 16 = 4). Hui katoa te 15 me te 4, ka 19, koia te  $\frac{1}{4}$  o te 76.

## Te Tau 3a

### Rapanga 4

1.3 rita te kītanga o tētahi ipu. E hia rita te kītanga o ētahi ipu e 4?



Kia tika te otinga (5.2 L) mā tētahi rautaki wāwāhi tau. Hei taurira:

1. Ka whakareatia te 1.3 ki te 2, ka 2.6. Ka whakareatia te 2.6 ki te 2, ka 5.2.

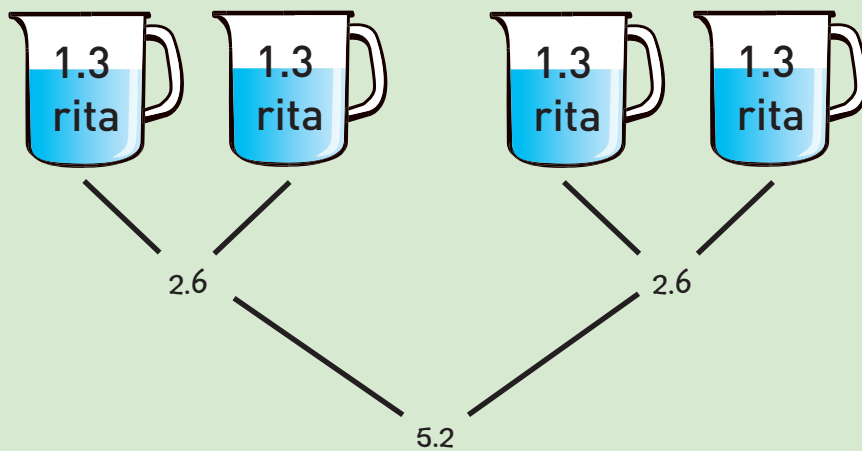

2. Ka wāwāhia te 1.3 ki te 1 me te 0.3. Ka whakareatia ēnei wāhanga e rua ki te 4, kātahi ka tāpiria.

$$\begin{aligned}
 1.3 \times 4 &= (1 \times 4) + (0.3 \times 4) \\
 &= 4 + 1.2 \\
 &= 5.2
 \end{aligned}$$

## Te Taura me te Pānga

Ngā Whāinga		
Ka whakaoti rapanga te ākonga, ka whakamārama otinga, e whai wāhi mai ana:	He taura ēnei o ngā āhuatanga me mātua mōhio te ākonga e tutuki ai tana whakaoti rapanga:	
<ul style="list-style-type: none"> <li>ngā taura tāpiripiri<sup>5</sup>, taura whakarea māmā, me ngā taura āhuahanga<sup>6</sup>, pānga hoki</li> <li>ngā taura o roto i te wāwāhitanga whakarea<sup>7</sup> o tētahi tau.</li> </ul>	<ul style="list-style-type: none"> <li>te pūmautanga o tētahi ture hei whakaahua i tētahi taura, tētahi pānga rānei.</li> </ul>	<sup>5</sup> additive pattern <sup>6</sup> geometric pattern  <sup>7</sup> multiplicative partitioning

## Te Reo Matatini o te Pāngarau

Hei taura kupu		
<ul style="list-style-type: none"> <li>ture</li> <li>taura raupapa</li> </ul>	<ul style="list-style-type: none"> <li>taura</li> <li>whārite</li> </ul>	<ul style="list-style-type: none"> <li>pānga</li> </ul>
Hei taura tohu		
<ul style="list-style-type: none"> <li>&lt;</li> </ul>	<ul style="list-style-type: none"> <li>&gt;</li> </ul>	<ul style="list-style-type: none"> <li>≠</li> </ul>
Hei taura whakaahuhanga		
<ul style="list-style-type: none"> <li>he tūtohi</li> </ul>	<ul style="list-style-type: none"> <li>he ripanga</li> </ul>	

## He Taura Rapanga

### Te Taura me te Pānga 3a

#### Rapanga 5

Whāia ēnei tohutohu, ka tuhi ai kia rima ngā tau o te taura raupapa:

- tīmata i te 15
- whakareatia te tau i mua ki te 2, ka tāpiri ai i te 5.

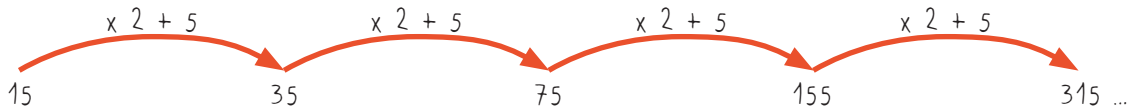

Kia tika te raupapa tau (15, 35, 75, 155, 315 ...), me te whakamārama i te rautaki hei whakaputa i ētahi o ngā tau.

Hei taura:

Ko te tau i mua i te tau tuatoru, ko te 35. Ka whakareatia ki te 2, ka 70, kātahi ka tāpiria te 5, ka 75.

### Te Taura me te Pānga 3a

#### Rapanga 6

Ko ngā whakaahua nei hei whakaatu i te tipu haere o tētahi taura tukutuku.

- E 4 ngā tuitui i te wāhanga 1 o te taura.
- E hia ngā tuitui i te wāhanga 18 o te taura?

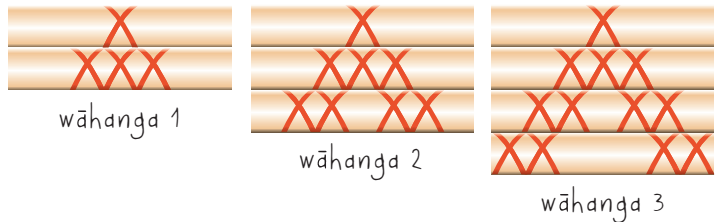

Kia tika te otinga (72) me te whakamārama i tētahi rautaki tāpiripiri māmā, rautaki whakarea māmā rānei. Hei taura:

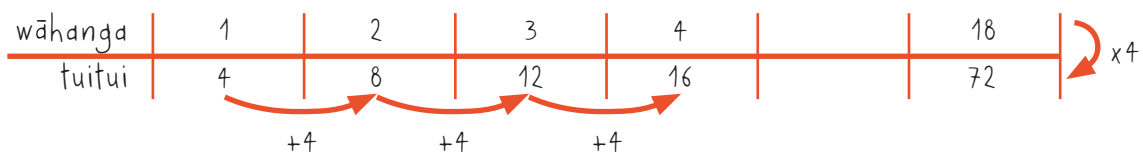

Ka tāpiria haeretia te 4. E 4 te maha ake o ngā tuitui o ia wāhanga.

Ka whakareatia te wāhanga ki te 4, ā, ka hua mai te maha o ngā tuitui.

## Te Tauira me te Pānga 3a

### Rapanga 7

Tekau tāra (\$10) te pūtea a Maioha hei hoko i ētahi pene rākau karakara me ētahi pene whītau. \$0.50 te utu mō te pene rākau karakara kotahi, \$1.00 te utu mō te pene whītau kotahi.



Whiriwhiria mēnā ka taea e Maioha ēnei hokonga:

- kia 4 ngā pene rākau karakara, kia 6 ngā pene whītau.
- kia 8 ngā pene rākau karakara, kia 5 ngā pene whītau.
- kia 7 ngā pene rākau karakara, kia 7 ngā pene whītau.

Kia whai rautaki ngā whiriwhiringa, pēnei i te whakaatu ki te tūtohi:

pene rākau karakara	pene whītau	te tapeke o te utu
$\$0.50 \times 4 = \$2$	$\$1 \times 6 = \$6$	\$8. He iti ake tēnei i te \$10.
$\$0.50 \times 8 = \$4$	$\$1 \times 5 = \$5$	\$9. He iti ake tēnei i te \$10.
$\$0.50 \times 7 = \$3.50$	$\$1 \times 7 = \$7$	\$10.50. He nui ake tēnei i te \$10.

## Te Ine me te Hanga

Ngā Whāinga		
Ka whakaoti rapanga te ākonga, ka whakamārama otinga, e whai wāhi mai ana:	He tauira ēnei o ngā āhuatanga me mātua mōhio te ākonga e tutuki ai tana whakaoti rapanga:	
<ul style="list-style-type: none"> <li>ngā momo āwhata<sup>8</sup> maha me ngā hautanga ā-ira o tētahi waeine<sup>9</sup></li> <li>ngā raumata<sup>11</sup> o ngā āhua ahu-3 māmā, pēnei i te mataono rite, te poro tapawhā hāngai, me te koeko tapawhā hāngai.</li> </ul>	<ul style="list-style-type: none"> <li>te whakamahi i ngā momo taputapu ine whānui (pērā i te ine-koki<sup>10</sup>).</li> </ul>	<sup>8</sup> scale <sup>9</sup> unit of measurement <sup>10</sup> protractor <sup>11</sup> net

## Te Reo Matatini o te Pāngarau

Hei tauira kupu		
<ul style="list-style-type: none"> <li>raumata</li> <li>waeine</li> <li>koki hāngai</li> </ul>	<ul style="list-style-type: none"> <li>ine-koki</li> <li>āwhata</li> </ul>	<ul style="list-style-type: none"> <li>tākiri/putu</li> <li>ahu-2, ahu-3</li> </ul>
Hei tauira tohu		
<ul style="list-style-type: none"> <li>o</li> </ul>		

## He Tauira Rapanga

### Te Ine me te Hanga 3a

#### Rapanga 8

**Rauemi:** He rūri, he ine-koki.

Tuhia tētahi tapatoru hāngai. Kia 12.7 cm te roa o tētahi tapa. Kia 35° te rahi o tētahi o ngā koki.

Kia tika te tuhi i te tapatoru hāngai (me te mōhio anō he aha te tapatoru hāngai), me te whakamahi i ngā taputapu ine. E tōtika ana te inenga roa (12.7 cm) me ngā inenga koki (90° me te 35°).

### Te Ine me te Hanga 3a

#### Rapanga 9

**Rauemi:** He rūri

E ringia ana e Pine te 2.5 rita wai ki roto i ngā ipu e toru nei. Āta whiriwhiria te teitei o te wai ki ia ipu, ka tohu ai.

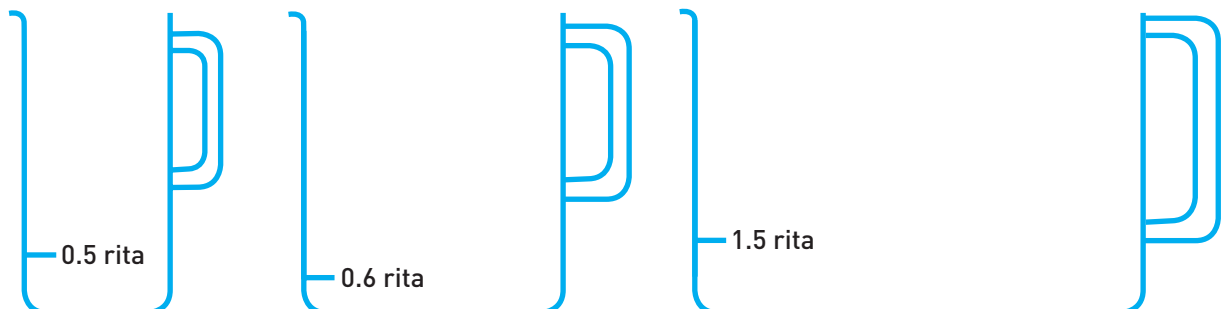

Kia tika te whiriwhiri i te āwhata o ngā ipu, me te tohu anō i te teitei o te 2.5 rita. Hei tauira:

**Mō te ipu tuatahi:** Ka whakareatia te inenga mō te 0.5 ki te 5, ā, ka whakamahia te rūri hei tohu i tēnei kītanga (te 2.5 rita) ki te ipu.

**Mō te ipu tuarua:** Ka whakareatia te inenga mō te 0.6 ki te 4, ā, ka whakamahia te rūri hei ine i tēnei kītanga (te 2.4 rita). Ka whakatau tata i te wāhi mō te 2.5 rita ki runga ake i te 2.4.

**Mō te ipu tuatoru:** Ka whakawehea te inenga mō te 1.5 rita ki te 3 (ko te inenga tēnei mō te 0.5 rita). Kātahi ka whakareatia tēnei ki te 5, ā, ka whakamahia te rūri hei tohu i tēnei kītanga (te 2.5 rita) ki te ipu.

Te Ine me te Hanga 3a

## Rapanga 10

*Rauemi:* He kāri (kia A3 te rahi), he rūri, he kutikuti, kia rua ngā pōro tēnehi, he tēpa whakapiri.

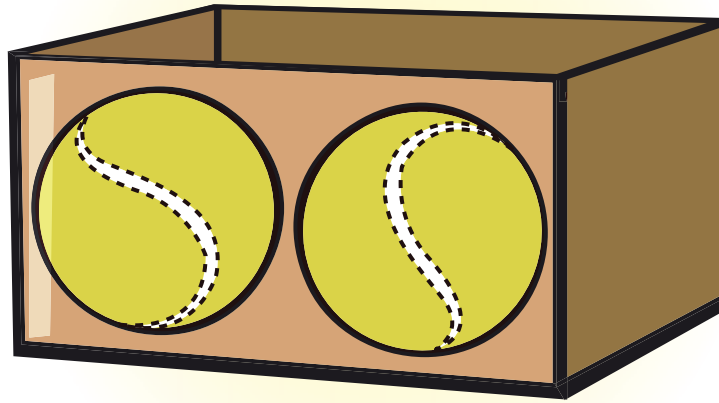

Tuhia te raumata o tētahi pouaka mō ngā pōro tēnehi e rua nei. Kāore he taupokī o te pouaka. Hangaia te pouaka.

**Kia tika te ine i ngā pōro tēnehi me te tuhi i te raumata. Ina whētua te raumata ka hua mai te pouaka, ā, ka uru ngā pōro ki roto.**



## Te Wāhi, te Ahunga, me te Panoni

Ngā Whāinga		
Ka whakaoti rapanga te ākonga, ka whakamārama otinga, e whai wāhi mai ana:	He tauira ēnei o ngā āhuatanga me mātua mōhio te ākonga e tutuki ai tana whakaoti rapanga:	
<ul style="list-style-type: none"> <li>te tukutuku<sup>12</sup>, te takirua raupapa<sup>13</sup>, ngā ahunga matua, me ngā mahere māmā hei whakaatu taunga, huarahi, panoni māmā hoki.</li> </ul>	<ul style="list-style-type: none"> <li>ngā ahunga matua e whā o te kāpehu<sup>14</sup> me ngā ahunga kei waenganui i ērā (pērā i te rāwhiti-mā-tonga)</li> <li>ngā tikanga o te whakaatu taunga ki tētahi pūnaha tukutuku.</li> </ul>	<p><sup>12</sup>grid</p> <p><sup>13</sup>ordered pair</p> <p><sup>14</sup>compass (for direction)</p>

## Te Reo Matatini o te Pāngarau

Hei tauira kupu		
<ul style="list-style-type: none"> <li>takirua raupapa</li> <li>mahere</li> <li>taunga</li> <li>rārangi whakaata</li> </ul>	<ul style="list-style-type: none"> <li>rāwhiti, rāwhiti-mā-tonga, uru-mā-tonga ...</li> <li>tukutuku</li> <li>kāpehu</li> </ul>	<ul style="list-style-type: none"> <li>whakaterāwhiti-mā-tonga, whakateuru-mā-raki ...</li> <li>ahunga</li> <li>pūwāhi</li> </ul>
Hei tauira whakaahuahanga		
<ul style="list-style-type: none"> <li>he papa tukutuku</li> </ul>	<ul style="list-style-type: none"> <li>he mahere</li> </ul>	<ul style="list-style-type: none"> <li>he takirua raupapa</li> </ul>

## He Tauira Rapanga

### Te Wāhi, te Ahunga, me te Panoni 3a

#### Rapanga 11

**Rauemi:** He mahere o Aotearoa.

Tirohia tētahi mahere o Aotearoa, ka whakautu ai i ngā pātai pēnei i ēnei:

- He aha tētahi tāone kei te raki o Te Whanganui-a-Tara?
- He aha tētahi tāone kei te rāwhiti-mā-tonga o Tāmakimakaurau?
- He aha te ahunga o te haere mai i Ahuriri ki Taranaki?
- Ka tīmata koe i Te Waihopai, ka haere whakatetonga. E haere ana koe ki hea?

**Kia tika te kimi i ngā wāhi i te mahere me te whakaatu i ngā ahunga.**

## Te Wāhi, te Ahunga, me te Panoni 3a

### Rapanga 12

**Rauemi:** He pepa tukutuku pēnei i te mea e whakaaturia ana i raro iho nei.

Tohua ēnei pūwāhi ki te tukutuku:

A: (2, 3) E: (2, 9) I: (8, 3) O: (8, 9)

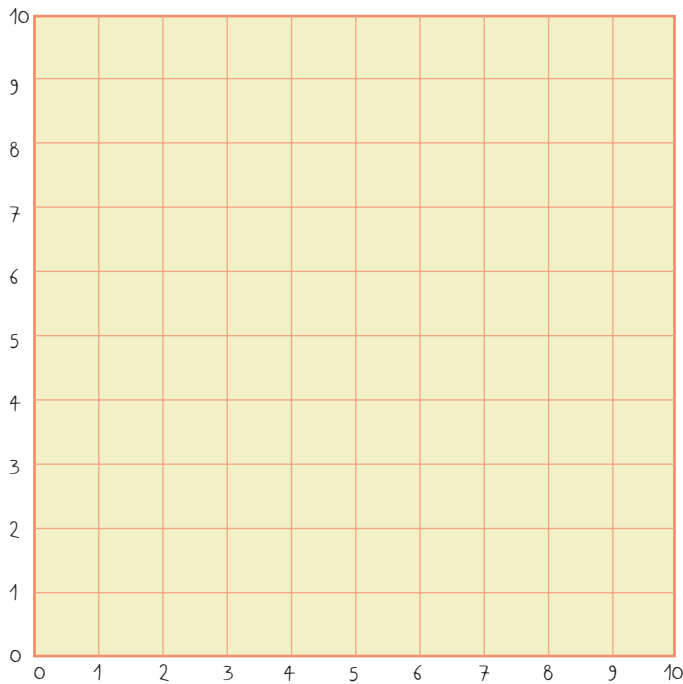

- He aha te ahunga mai i te A ki te E?
- He aha te ahunga mai i te I ki te A?
- He aha te ahunga mai i te O ki te A?
- Ka tīmata i te E, ka haere whakaterāwhiti-mā-tonga. Ka tae atu ki hea?

Kia tika te whakaatu i ngā pūwāhi ki te tukutuku me te whiriwhiri hoki i ngā ahunga.

## Te Wāhi, te Ahunga, me te Panoni 3a

### Rapanga 13

**Rauemi:** He pepa tukutuku.

Tuhia te whakaatatanga o te tapatoru i te rārangi AE:

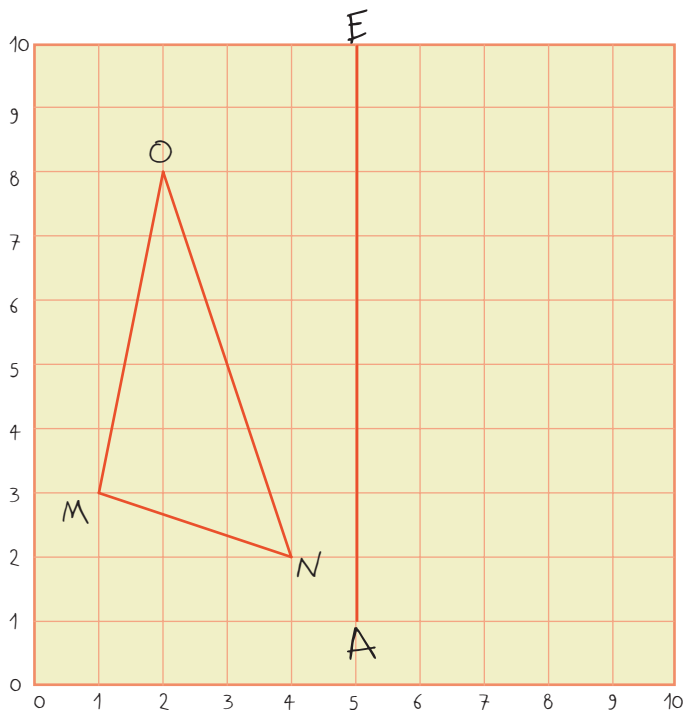

He aha ngā pūwāhi whakaata o te M, te N, me te O?

Kia tika te whakaatu i te tapatoru whakaata me te tautohu i ōna akitu.

## Te Tauanga

Ngā Whāinga		
Ka whakaoti rapanga te ākongā, ka whakamārama otinga, e whai wāhi mai ana:	He tauira ēnei o ngā āhuetanga me mātua mōhio te ākongā e tutuki ai tana whakaoti rapanga:	
<ul style="list-style-type: none"> <li>te whakatakoto pātai e hāngai ana, me te kohikohi raraunga hei tūhura i te pātai</li> <li>te raraunga motukore<sup>15</sup> (pērā i te raraunga houanga<sup>16</sup>)</li> <li>te whakaputa kōrero mō ngā tauira, ngā ia, me ngā āhuetanga kōhure o tētahi huinga raraunga.</li> </ul>	<ul style="list-style-type: none"> <li>te whakaatu raraunga ki te kauwhata rārangi</li> <li>te āhua o te whakaaringa raraunga hei whakaatu ngā ia<sup>17</sup>, ngā tauira, me ngā āhuetanga kōhure<sup>18</sup> o roto i ngā raraunga.</li> </ul>	<p><sup>15</sup>continuous data</p> <p><sup>16</sup>time-series data</p> <p><sup>17</sup>trends</p> <p><sup>18</sup>distinctive features</p>

## Te Reo Matatini o te Pāngarau

Hei tauira kupu		
<ul style="list-style-type: none"> <li>huinga raraunga</li> <li>tuaka pae</li> </ul>	<ul style="list-style-type: none"> <li>kauwhata rārangi</li> <li>tuaka pou</li> </ul>	<ul style="list-style-type: none"> <li>ia</li> </ul>
Hei tauira whakaahuhanga		
<ul style="list-style-type: none"> <li>he kauwhata rārangi</li> </ul>	<ul style="list-style-type: none"> <li>he ripanga</li> </ul>	

## He Tauira Rapanga

### Te Tauanga 3a

### Rapanga 14

**Rauemi:** He pepa tukutuku, he rorohiko rānei me tētahi hōtaka ripanga.

Koia nei ngā inenga paemahana mō Taupō me Whāngārei i ngā hōra mai i te 6:00 i te ata ki te 8:00 i te pō i tētahi rangi:

	6	7	8	9	10	11	12	1	2	3	4	5	6	7	8
Whāngārei	12°	12°	13°	14°	15°	17°	19°	20°	20°	21°	20°	18°	13°	12°	11°
Taupō	2°	3°	5°	8°	12°	15°	19°	20°	21°	19°	17°	15°	13°	11°	9°

- Whakaaturia ngā inenga paemahana nei ki tētahi kauwhata. Whakamāramatia mai te take i whiriwhiria e koe tēnā momo kauwhata.
- He aha ētahi kōrero e kitea mai ana i ngā kauwhata?
- Me whakatau tata te paemahana i ngā wāhi e rua nei i te 5:30 i te ahiahi pō.

Kia tika te whakaatu i ngā raraunga ki tētahi kauwhata rārangi (mā te ringa, mā te rorohiko rānei), arā:

- ko te hōra o te rā ki te tuaka pae, ko te paemahana ki te tuaka pou
- ko te honohono i ngā pūwāhi o te kauwhata ki tētahi rārangi
- ko te whakamahi tae rerekē hei tohu i ngā paemahana mō Taupō me ērā mō Whāngārei.

Ka whakamārama i te take e tika ana te kauwhata rārangi.

Ka whakaputa kōrero mō ētahi āhuetanga kōhure o te kauwhata. Hei tauira:

- Ka tino piki te paemahana i Taupō, mai i te 2° ki te 21°.
- Kāore i te pērā rawa te piki o te paemahana i Whāngārei (mai i te 12° ki te 21°).
- Ka heke te paemahana i Whāngārei ki te paemahana āhua rite ki tērā i te tīmatanga o te rā.
- Kāore i te pērā rawa te heke o te paemahana i Taupō i te ahiahi pō.
- I te ata, he makariri ake a Taupō i Whāngārei, engari ka piki ki te paemahana ōrite i waenganui rā.

Ka whakamahia te kauwhata ki te whakatau tata i te paemahana i ngā wāhi e rua nei i te 5:30 i te ahiahi pō, arā, kei te takiwā o te 15° i Whāngārei, kei te āhua 14° i Taupō.

## Te Tūponotanga

Ngā Whāinga		
Ka whakaoti rapanga te ākongā, ka whakamārama otinga, e whai wāhi mai ana:	He tauira ēnei o ngā āhuetanga me mātua mōhio te ākongā e tutuki ai tana whakaoti rapanga:	
<ul style="list-style-type: none"> <li>te tūhura pūāhua tūponotanga<sup>19</sup> māmā, pēnei i te piu i tētahi uka, me te pīrori i tētahi mataono tau</li> <li>te whakaatu tūponotanga hei hautau māmā i waenganui i te kore me te kotahi.</li> </ul>	<ul style="list-style-type: none"> <li>te whakatairite i ngā putanga matapae<sup>20</sup> me ngā putanga whakamātau<sup>21</sup> o tētahi pāpono tūponotanga</li> <li>te wehe kētanga<sup>22</sup>, te whakawhirinaki<sup>23</sup>, te aukati<sup>24</sup> rānei o ētahi pāpono e rua.</li> </ul>	<p><sup>19</sup>probability situation</p> <p><sup>20</sup>theoretical outcome</p> <p><sup>21</sup>experimental outcome</p> <p><sup>22</sup>independent, <sup>23</sup>dependent</p> <p><sup>24</sup>mutually exclusive</p>

## Te Reo Matatini o te Pāngarau

Hei tauira kupu		
<ul style="list-style-type: none"> <li>putanga</li> <li>pāpono whakawhirinaki</li> <li>putanga matapae</li> </ul>	<ul style="list-style-type: none"> <li>pāpono</li> <li>pāpono aukati</li> <li>putanga whakamātau</li> </ul>	<ul style="list-style-type: none"> <li>pāpono wehe kē</li> <li>matapōkere</li> </ul>

## He Tauira Rapanga

### Te Tūponotanga 3a

### Rapanga 15

E ono ngā poi kei roto i tētahi pouaka, e rua he kahurangi, e toru he kōwhai, he karaka tētahi. He ōrite te rahi o ngā poi katoa.

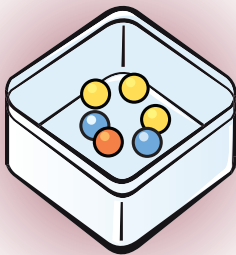

1. Ina tangohia matapōkerehia tētahi o ngā poi, he aha te tūponotanga ka puta he mea kōwhai?
2. Ina tangohia matapōkerehia tētahi o ngā poi, he aha te tūponotanga ka puta he mea kōwhai, he mea karaka rānei?
3. Ina tangohia matapōkerehia tētahi o ngā poi, he aha te tūponotanga ka puta he mea whero?

Kia tika te whakaatu i ngā tūponotanga me ngā whakamārama pēnei i ēnei:

- E toru ngā poi kōwhai o roto i ngā poi e ono katoa. Nō reira e toru o roto i te ono ( $\frac{3}{6}$ ) te tūponotanga o tētahi poi kōwhai. He ōrite tēnā ki te haurua ( $\frac{1}{2}$ ), nā te mea he kōwhai te tae o te haurua o ngā poi e ono katoa.
- E toru ngā poi kōwhai, kotahi te poi karaka, ka whā tēnā o roto i te ono. Nō reira e whā o roto i te ono ( $\frac{4}{6}$ ,  $\frac{2}{3}$ ) te tūponotanga o tētahi poi kōwhai, poi karaka rānei.
- Ko te kore te tūponotanga o tētahi poi whero, nā te mea karekau he poi whero i roto i te pouaka.

### Te Tūponotanga 3a

### Rapanga 16

**Rauemi:** Ngā mea hei hanga i tētahi pūrere takahurihuri.

1. Hangaia tētahi pūrere takahurihuri ko te  $\frac{3}{8}$  te tūponotanga ka tau te pūrere ki te whero.
2. Mēnā e 8 ngā takahurihanga o te pūrere, e hia pea ngā taunga ki te rohe whero?

1. Kia tika te whakaatu i ngā hauwaru ki te porowhita me te karakara kia whero ngā hauwaru e toru.
2. Kia tika te whakamārama mō te rerekē o te putanga matapae me te putanga whakamātau. Hei tauira:
  - Ko te matapae, ka 3 ngā taunga ki te rohe whero o roto i ngā takahurihanga e 8 o te pūrere, engari ki te whakamātau, ka nui ake, ka iti iho pea i te toru. Ko te  $\frac{3}{8}$  te tūponotanga, engari he matapōkere ia takahurihanga o te pūrere, kāore e mōhiohia ana ka tau ki hea.

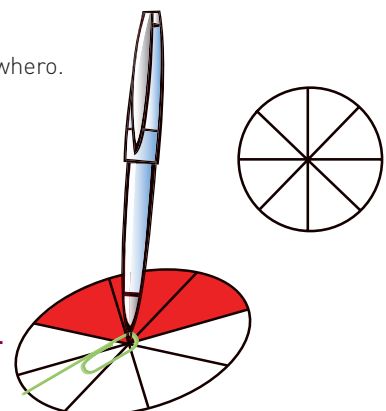

## Te Tau: Te Mātauranga Tau me ngā Rautaki Tau

(TPT) Kaupae 6

Ngā Whāinga		
Ka whakaoti rapanga te ākonga, ka whakamārama otinga, e whai wāhi mai ana:	He tauira ēnei o ngā āhuatanga me mātua mōhio te ākonga e tutuki ai tana whakaoti rapanga:	
<ul style="list-style-type: none"> <li>ngā rautaki whakarea<sup>1</sup> mō te whakareatanga, te whakawehenga, me te whiriwhiri hautanga o tētahi tauoti.</li> </ul>	<ul style="list-style-type: none"> <li>ngā tauoti mai i te 0 ki te 1 000 000 me tua atu, ngā hautau noa, ngā tau ā-ira (kia 3 ngā mati ā-ira), me te mātauranga uara tū<sup>2</sup> e hāngai ana</li> <li>ngā hononga whānui o ngā meka matua pērā i te <math>3 \times 0.4 = 1.2</math></li> <li>te whakaawhiwhi<sup>3</sup> tauoti hei whakatau tata<sup>4</sup> i te otinga o tētahi paheko tau<sup>5</sup></li> <li>te raupapa hautau.</li> </ul>	<p><sup>1</sup>multiplicative strategy</p> <p><sup>2</sup>place value</p> <p><sup>3</sup>round</p> <p><sup>4</sup>estimate</p> <p><sup>5</sup>number operation</p>

## Te Reo Matatini o te Pāngarau

Hei tauira kupu		
<ul style="list-style-type: none"> <li>tau ā-ira</li> <li>whakaawhiwhi</li> </ul>	<ul style="list-style-type: none"> <li>hautanga ā-ira</li> <li>whakatau tata</li> </ul>	<ul style="list-style-type: none"> <li>mati ā-ira</li> <li>ōrau</li> </ul>
Hei tauira whakaahuahanga		
<ul style="list-style-type: none"> <li>te tukutuku me te tapawhā hāngai hei whakatauira whakareatanga</li> </ul>		

## He Tauira Rapanga

Te Tau 3e

### Rapanga 1

E 5 ngā paepae hēki i hokona e Māka, e 36 ngā hēki kei ia paepae. E hia katoa ngā hēki i hokona e Māka?

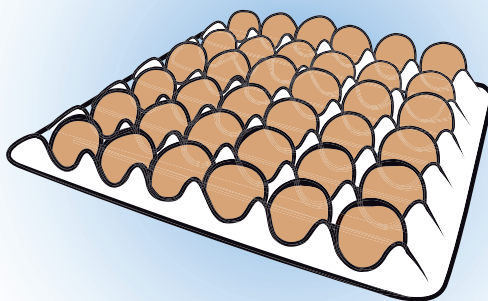

Kia tika te otinga (180), mā tētahi rautaki wāwāhi tau pēnei i ēnei:

1

- Ka whakareatia te 36 ki te 10, kātahi ka whakahaurua.

$$\begin{aligned}
 36 \times 5 &= 36 \times 10 \div 2 \\
 &= 360 \div 2 \\
 &= 180
 \end{aligned}$$

2

- Ka wāwāhia te 36 ki te 30 me te 6, ā, ka whakareatia ia wāhanga ki te 5.

$$\begin{aligned}
 36 \times 5 &= (30 \times 5) + (6 \times 5) \\
 &= 150 + 30 \\
 &= 180
 \end{aligned}$$

## Te Tau 3e

### Rapanga 2

E tākaro kirikiti ana ngā "Pōtae Pango" o Aotearoa. E 597 ngā omanga i te wāhanga tuatahi o te kēmu, e 209 i te wāhanga tuarua. E hia katoa ngā omanga o Aotearoa i tēnei kēmu?

Kia tika te otinga (806), mā tētahi rautaki wāwāhi tau pēnei i ēnei:

- 1 • Ka whakaawhiwhia te 597 ki te 600, ka tāpiri i te 209, kātahi ka tango i te 3.

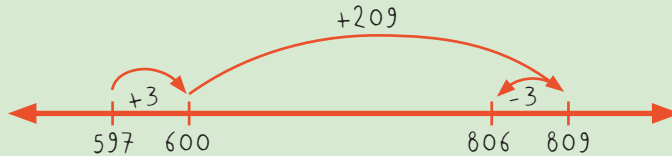

- 2 • Ka tāpiria te 3 ki te 597, ka tangohia te 3 i te 209, kātahi ka tāpirihia.

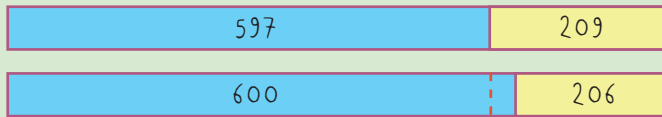

- 3 • Ka tāpiria te 200 ki te 597, kātahi ka tāpiri i te 9.

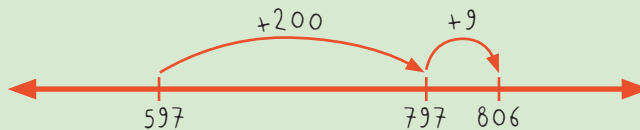

## Te Tau 3e

### Rapanga 3

Tokowhā ngā tāngata kei roto i tētahi rōpū e kato āporo ana. \$108 te whiwhinga a te rōpū, ka wehea kia ōrite te whiwhinga a ia tangata. E hia te whiwhinga a ia tangata?

Kia tika te otinga (\$27), mā tētahi rautaki wāwāhi tau pēnei i ēnei:

- 1 • Ka wāwāhia te 108 ki te 100 me te 8, ka whakawehea ia wāhanga ki te 4.

$$\begin{aligned} 108 \div 4 &= (100 \div 4) + (8 \div 4) \\ &= 25 + 2 \\ &= 27 \end{aligned}$$

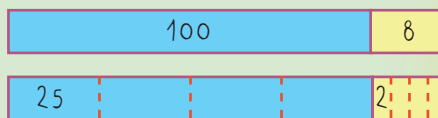

- 2 • Ka hauruatia te 108, ka hauruatia anō.

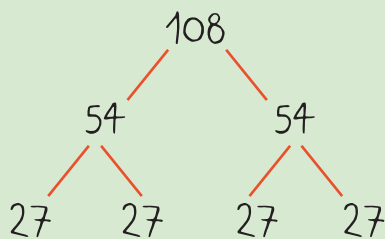

- 3 • Ka huri kōaro hei whakareatanga.

$$\begin{aligned} 108 \div 4 &= \square \longleftrightarrow \square \times 4 = 108 \\ 25 \times 4 &= 100 \\ \underline{2 \times 4} &= \quad 8 \\ 27 \times 4 &= 108 \end{aligned}$$



## Te Tau 3e

### Rapanga 4

E 6.4 rita wai ārani hei whakakāi i ngā kapu e 8. E hia rita wai ārani ki ia kapu?

Kia tika te otinga (0.8 rita), mā tētahi rautaki wāwāhi tau pēnei i ēnei:



- 1 • Mā te mōhio ki te meka whakawehenga  $64 \div 8 = 8$ , ka whakawhānuitia ki te  $6.4 \div 8$ .

- 2 • Mā te whakahaurua.

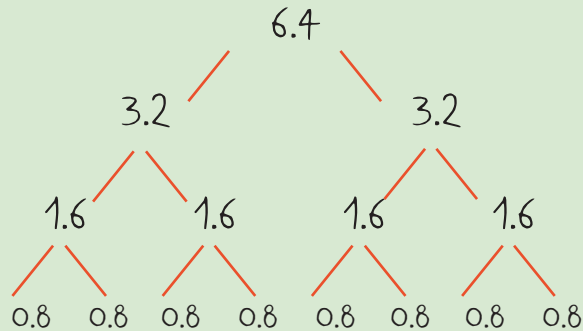

## Te Tau 3e

### Rapanga 5

E 8 ngā poro tiakareti ka wehea ki ētahi tāngata tokotoru kia ōrite te whiwiringa a tēnā me tēnā. E hia ngā poro tiakareti ka riro i ia tangata?

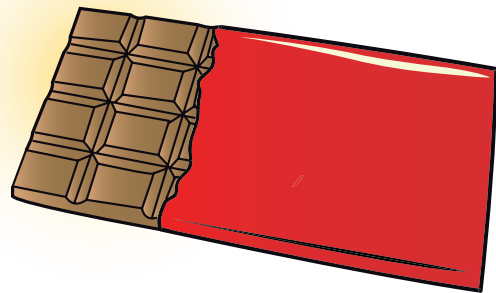

Kia tika te otinga ( $2\frac{2}{3}$ ), mā tētahi rautaki wāwāhi tau pēnei i ēnei:

- 1 • Ka wāwāhia te 8 ki te 6, te 1 me te 1, kātahi ka whakawehea ia wāhanga ki te 3.

$$\begin{aligned} 8 \div 3 &= (6 \div 3) + (1 \div 3) + (1 \div 3) \\ &= 2 + \frac{1}{3} + \frac{1}{3} \\ &= 2\frac{2}{3} \end{aligned}$$

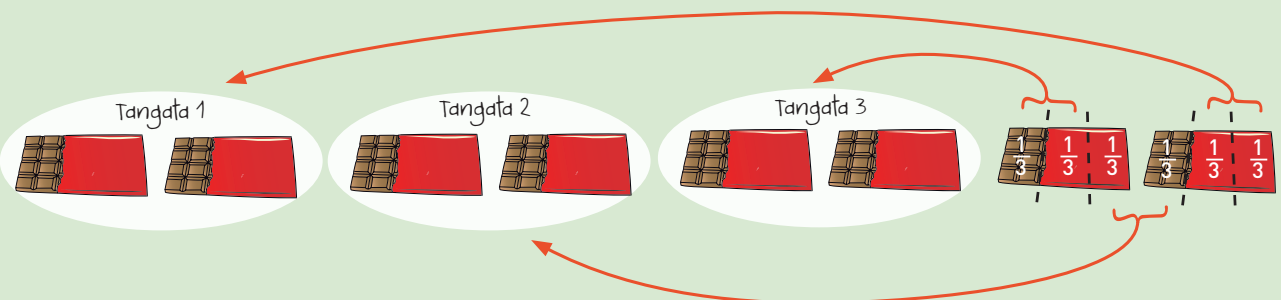

2

• Ka huri kōaro hei whakareatanga.

$$8 \div 3 = \square \longleftrightarrow \square \times 3 = 8$$

$$2 \times 3 = 6$$

$$\frac{1}{3} \times 3 = 1$$

$$\frac{1}{3} \times 3 = 1$$

$$2 \frac{2}{3} \times 3 = 8$$

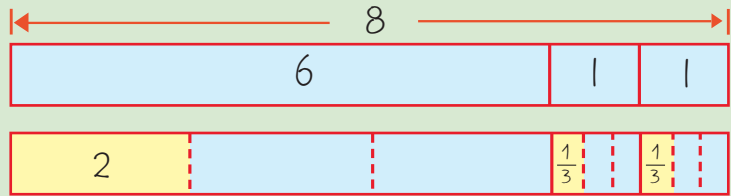

Te Tau 3e

## Rapanga 6

Ka riro i a Hēmi te  $\frac{3}{8}$  o tētahi pūtea. Ka riro i a Waiora te  $\frac{1}{4}$ , ā, ka riro i a Māia te toenga. Ka riro i a wai te wāhanga iti rawa atu?

Kia tika te otinga (ka riro i a Waiora te wāhanga iti rawa atu), me tētahi whakamārama pēnei:

Ka whakaaturia ngā hautanga ki tētahi porowhita, ki ētahi poraka hautau rānei, kia āta kitea te rahi o ia wāhanga:

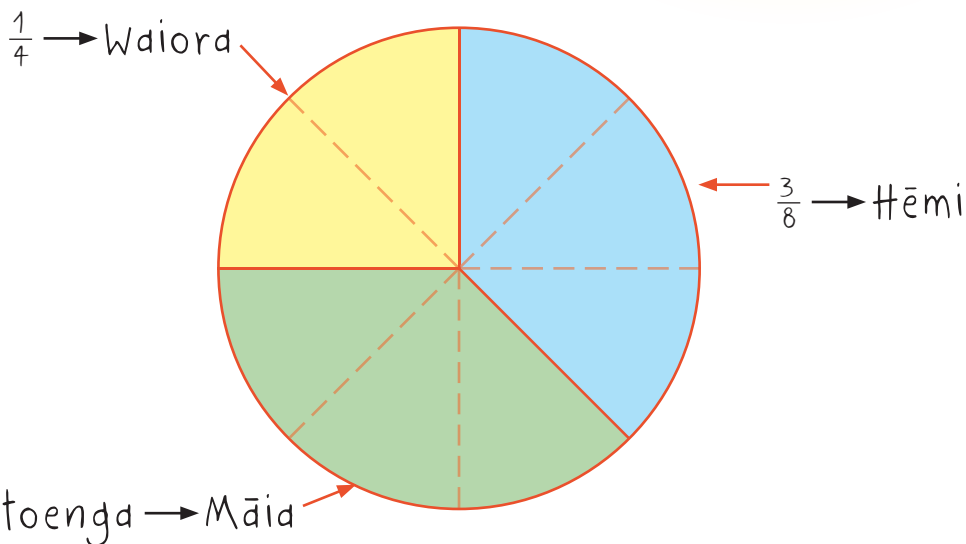

Ka wāwāhia te porowhita hei whakaatu i ngā hauwaru ( $\frac{1}{8}$ ). Ka karangia te  $\frac{3}{8}$  hei tohu i te hautanga ki a Hēmi, me te  $\frac{1}{4}$  hei tohu i te hautanga ki a Waiora. Ko te toenga hei tohu i te hautanga ki a Māia. He ōrite te whiwhinga pūtea a Hēmi rāua ko Māia – ka riro i a rāua ngā wāhanga nui ake o te pūtea (he  $\frac{3}{8}$  ki tēnā, ki tēnā). He iti iho te pūtea ka riro i a Waiora, ko tāna te wāhanga iti rawa atu ( $\frac{1}{4}$ ).



## Te Taura me te Pānga

Ngā Whāinga		
Ka whakaoti rapanga te ākonga, ka whakamārama otinga, e whai wāhi mai ana:	He tauira ēnei o ngā āhuatanga me mātua mōhio te ākonga e tutuki ai tana whakaoti rapanga:	
<ul style="list-style-type: none"> <li>ngā rautaki taurangi<sup>6</sup> māmā e hāngai ana ki tētahi taura, ki tētahi pānga māmā rānei (pēnei i te pānga tāpiripiri me te pānga whakarea).</li> </ul>	<ul style="list-style-type: none"> <li>te tikanga o te taurangi<sup>7</sup> hei whakaatu i tētahi rahinga<sup>8</sup> kāore e mōhiohia ana, me te whakamahinga o te pū (reta) hei tohu taurangi.</li> </ul>	<sup>6</sup> algebraic strategy <sup>7</sup> variable <sup>8</sup> quantity

## Te Reo Matatini o te Pāngarau

Hei tauira kupu		
• taurangi	• pānga	• whārite taurangi
Hei tauira whakaahuahanga		
• tūtohi	• whārite	

## He Taura Rapanga

### Te Taura me te Pānga 3e

#### Rapanga 7

E whakarite ana a Mahora i ngā tēpu me ngā tūru o te whare kai. Ka 6 ngā tāngata ka noho ki ia tēpu. Arā:

ngā tēpu	1	2	3	4
ngā tūru	6	12	18	24

- Whakamāramatia te ture hei tātai i te maha o ngā tūru.
- Tuhia te whārite hei tātai i te maha o ngā tūru.
- Ka hia ngā tūru mēnā 16 ngā tēpu?
- Tuhia te whārite hei tātai i te maha o ngā tēpu.
- Ka hia ngā tēpu mēnā e 72 ngā tūru?

#### Hei tauira whakautu:

- Ka whakareatia te maha o ngā tēpu ki te 6 hei tātai i te maha o ngā tūru. Arā, e 6 ngā tūru ki ia tēpu.
- $tū = tē \times 6$  ( $tū =$  tūru,  $tē =$  tēpu)
- $6 \times 16 = 96$  E 96 ngā tūru.
- $tē = tū \div 6$  ( $tū =$  tūru,  $tē =$  tēpu)
- $72 \div 6 = 12$  12 ngā tēpu.

### Te Taura me te Pānga 3e

#### Rapanga 8

He tauira raupapa tēnei kua hangaia ki runga i te papa tīrau. Mēnā ka haere tonu te tauira nei, ka pēhea te āhua o te papa tīrau 39?

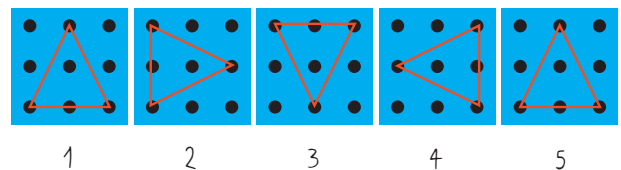

**Ka whakamārama te ākonga i te raupapa haere o te tauira, arā, he huringa hauwhā whakatekaraka.**

**Ka āta kite te ākonga i te tāruaruatanga o ngā papa tīrau mai i te tuatahi ki te tuawhā. Arā:**

- te papa tīrau 1: he ōrite ki ngā papa tīrau 5, 9, 13, 17 ...  
 te papa tīrau 2: he ōrite ki ngā papa tīrau 6, 10, 14, 18 ...  
 te papa tīrau 3: he ōrite ki ngā papa tīrau 7, 11, 15, 19 ...  
 te papa tīrau 4: he ōrite ki ngā papa tīrau 8, 12, 16, 20 ...

Nō reira, ka ōrite te papa tīrau 40 ki te papa tīrau 4, ā, ka ōrite te papa tīrau 39 ki te papa tīrau 3.

## Te Ine me te Hanga

Ngā Whāinga		
Ka whakaoti rapanga te ākonga, ka whakamārama otinga, e whai wāhi mai ana:	He tauira ēnei o ngā āhuetanga me mātua mōhio te ākonga e tutuki ai tana whakaoti rapanga:	
<ul style="list-style-type: none"> <li>te whakatau tata me te whiriwhiri horahanga māmā, rōrahi māmā</li> <li>te tuhi raumata<sup>10</sup> o ngā āhua ahu-3<sup>11</sup> whānui.</li> </ul>	<ul style="list-style-type: none"> <li>ngā waeine<sup>9</sup> e tika ana mō te horahanga me te rōrahi, pēnei i te <math>\text{cm}^2</math>, te <math>\text{cm}^3</math>, te <math>\text{m}^2</math>, me te <math>\text{m}^3</math></li> <li>te whakamahi tukutuku<sup>12</sup> hei whiriwhiri horahanga</li> <li>te whakamahi mataono rite<sup>13</sup> hei whiriwhiri rōrahi.</li> </ul>	<p><sup>9</sup>unit of measurement</p> <p><sup>10</sup>net</p> <p><sup>11</sup>3-dimensional shape</p> <p><sup>12</sup>grid</p> <p><sup>13</sup>cube</p>

## Te Reo Matatini o te Pāngarau

Hei tauira kupu		
<ul style="list-style-type: none"> <li>raumata</li> <li>mitarau pūrua</li> </ul>	<ul style="list-style-type: none"> <li>horahanga</li> <li>mitarau pūtoru</li> </ul>	<ul style="list-style-type: none"> <li>rōrahi</li> <li>rita</li> </ul>
Hei tauira tohu		
<ul style="list-style-type: none"> <li><math>\text{cm}^2</math>, <math>\text{m}^2</math></li> </ul>	<ul style="list-style-type: none"> <li><math>\text{cm}^3</math>, <math>\text{m}^3</math></li> </ul>	<ul style="list-style-type: none"> <li>L, mL</li> </ul>

## He Tauira Rapanga

Te Ine me te Hanga 3e

### Rapanga 8

Kua hangaia he pouaka hei tākai i ngā mataono rite. E 20 cm ki te 20 cm ki te 10 cm ngā tapa o te pouaka.



- E hia ngā mataono rite, 1 cm ki te 1 cm ki te 1 cm ka uru ki te pouaka?
- E hia ngā mataono rite, e 2 cm ki te 2 cm ki te 2 cm ka uru ki te pouaka?

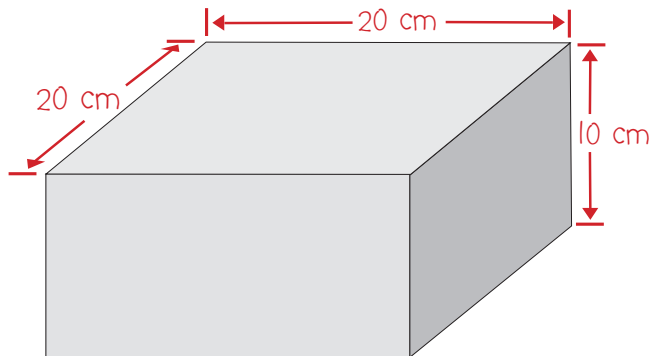

Kia tika te whiriwhiri i te rōrahi me te whakaatu anō i te mōhio ki te tikanga o te rōrahi. Hei tauira:

- Ka tātaihia te maha o ngā  $\text{cm}^3$  ka takoto ki te papa o te pouaka (mā te whakarea  $20 \times 20 = 400$ ), kātahi ka tātaihia te maha o ngā paparanga  $\text{cm}^3$  (mā te whakarea  $400 \times 10 = 4\ 000$ ).

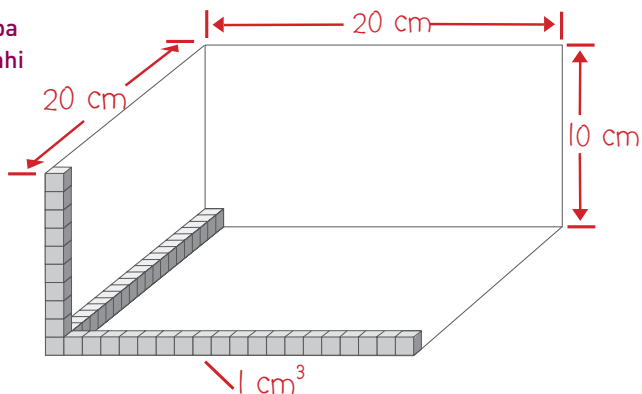

2. Ka tātaihia te maha o ngā mataono rite  $2\text{ cm}^3$  ka takoto ki te papa o te pouaka (mā te whakarea  $10 \times 10 = 100$ ), kātahi ka tātaihia te maha o ngā paparanga o ngā mataono  $2\text{ cm}^3$  (mā te whakarea  $100 \times 5 = 500$ )

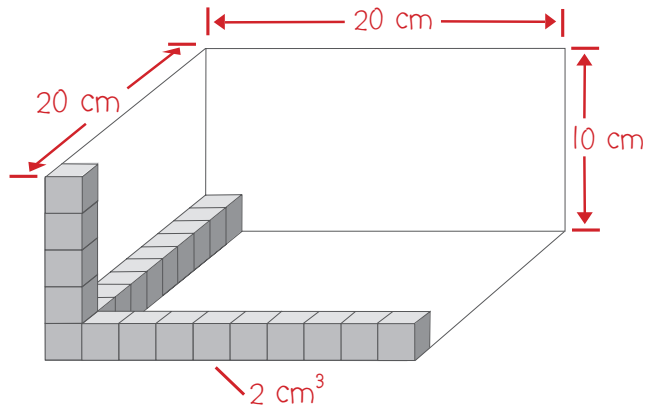

## Te Ine me te Hanga 3e

### Rapanga 9

Ko ēhea o ēnei he raumata mataono rite? (Arā, ina whētua ka hua mai he mataono rite.)

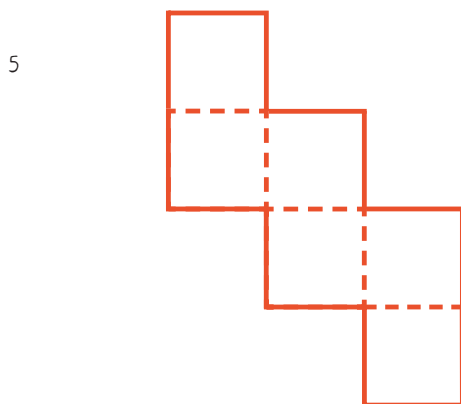
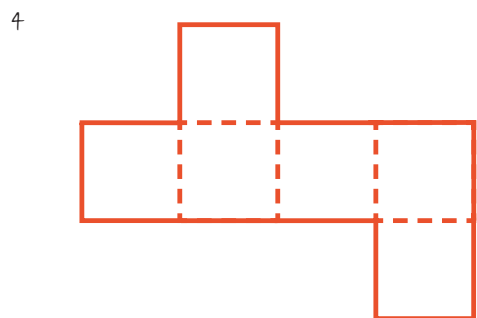
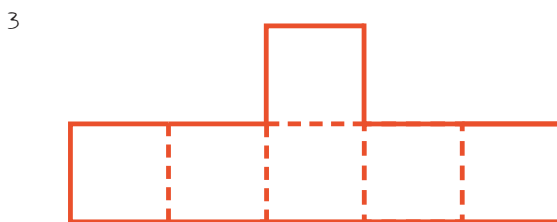
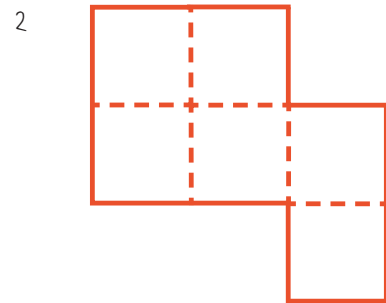
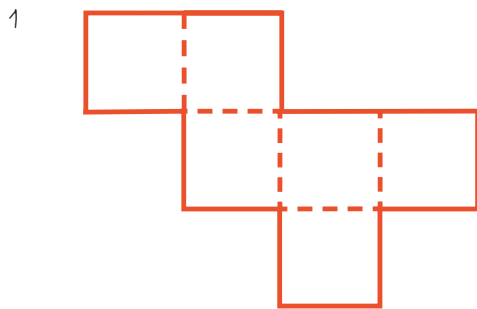

Mēnā e 5 cm te roa o ia tapa o te mataono rite, he aha tōna rōrahi?

Ka mārama te ākonga ki te āhua o te mataono rite, me ngā raumata e hangaia ai he mataono rite.

Kia tika te tātai i te rōrahi me te hoatu i te waeine e tika ana. Arā,  $5 \times 5 \times 5$  ( $5^3$  rānei) =  $125\text{ cm}^3$

## Te Wāhi, te Ahunga, me te Panoni

Ngā Whāinga		
Ka whakaoti rapanga te ākonga, ka whakamārama otinga, e whai wāhi mai ana:	He tauira ēnei o ngā āhuratanga me mātua mōhio te ākonga e tutuki ai tana whakaoti rapanga:	
<ul style="list-style-type: none"> <li>te hanga me te whakamārama tauira ka hua mai i te <b>panoni tāruarua</b><sup>14</sup></li> <li>ngā panoni matua e hua mai ai te <b>mātātuhi</b><sup>15</sup> i tōna <b>mātāoroko</b><sup>16</sup>.</li> </ul>	<ul style="list-style-type: none"> <li>ngā tikanga mō te whakamārama panoni (pērā i te pū me te koki o te hurihanga, te rārangi whakaata, te rahi me te ahunga o te neke, me te <b>taurahi</b><sup>17</sup> o tētahi whakarahinga māmā).</li> </ul>	<p><sup>14</sup>repetitive transformation</p> <p><sup>15</sup>image</p> <p><sup>16</sup>object</p> <p><sup>17</sup>scale factor</p>

## Te Reo Matatini o te Pāngarau

Hei tauira kupu		
<ul style="list-style-type: none"> <li>panoni tāruarua</li> <li>taurahi</li> </ul>	<ul style="list-style-type: none"> <li>mātātuhi</li> <li>pū huringa</li> </ul>	<ul style="list-style-type: none"> <li>mātāoroko</li> <li>pū whakarahi</li> </ul>
Hei tauira whakaahuhanga		
<ul style="list-style-type: none"> <li>te papa tukutuku</li> </ul>		

## He Tauira Rapanga

Te Wāhi, te Ahunga, me te Panoni 3e

### Rapanga 10

**Rauemi:** He tauira tāruarua.



Tonoa te ākonga kia whakamārama i ngā panoni tāruarua o roto i ētahi tauira pēnei i ngā tauira e rua nei. E pai ana kia tukuna he pātai pēnei i ēnei hei kukume i ngā whakaaro o te ākonga:

- Ki hea te rārangi whakaata?
- Tohua mai te pū o te huringa.
- He aha te wāhanga o te tauira e tāruaruatia ana?

Kia tika ngā whakamārama me te whakamahi anō i ngā kupu e hāngai ana mō te panoni.

Kia tika hoki te tautohu i ngā āhuratanga panoni, pēnei i ēnei:

- te rārangi hangarite
- te pū huringa
- te rahi o te huringa
- te ahunga o te neke
- te tawhiti o te neke
- te wāhanga o te tauira e whakaatanga ana, e nekehia ana, e hurihia ana rānei.

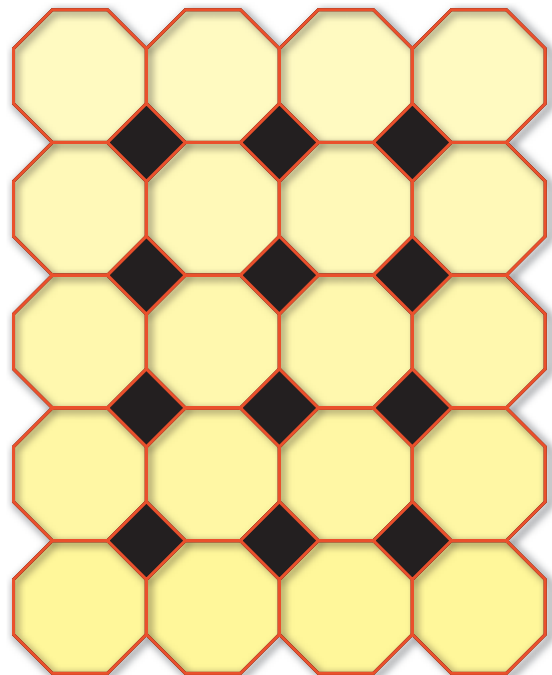

## Rapanga 11

Rauemi: He pepa tukutuku.

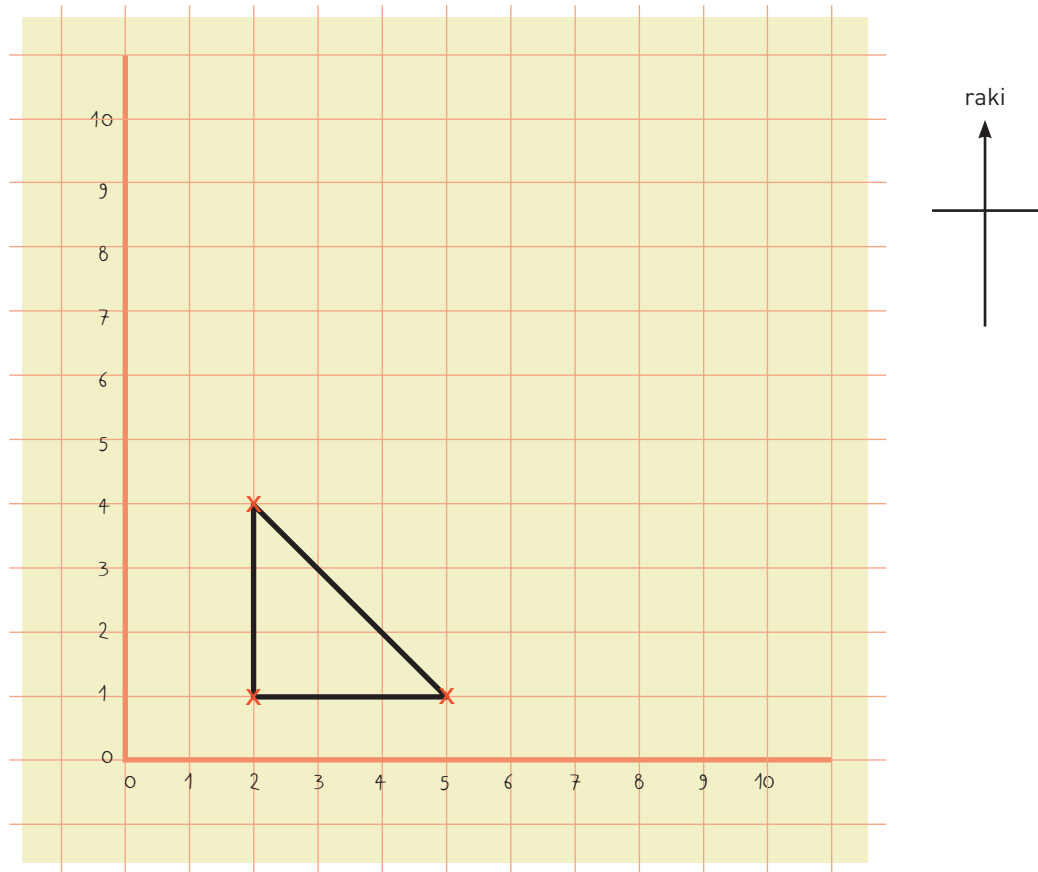

Tonoa te ākongā kia honoa ētahi pūwāhi i te tukutuku hei tuhi i tētahi āhua, pēnei i te tapatoru i runga nei. Ko ōna akitu, ko te (2,1), ko te (5,1), ko te (2,4). Hoatu he tohutohu mō ētahi panoni hei tuhi mā te ākongā i te mātātuhī. Hei tauira:

- Tuhia te whakarahinga o te tapatoru. Ko te pūwāhi (2,1) te pū whakarahi, ko te 3 te taurahi. He aha ngā pūwāhi o ngā akitu o te tapatoru whakarahi?
- Whakaatanga te tapatoru. Ko te tapa roa o te tapatoru hei rārangi whakaata. He aha ngā pūwāhi o ngā akitu o te tapatoru whakaata?
- Hurihia te tapatoru. Ko te (2,4) te pū huringa. Kia  $90^\circ$  kōaro te rahi o te huringa. He aha ngā pūwāhi o ngā akitu o te tapatoru mātātuhī?
- Nekehia te tapatoru. Kia 3 cm whakaterāwhiti-mā-raki te nekehanga. He aha ngā pūwāhi o ngā akitu o te tapatoru mātātuhī?

**Kia tika te tuhi i te tapatoru mātāoroko, me te whakaatu anō i ngā panoni ki te pepa tukutuku. Ka tuhia ngā takirua raupapa hei whakaatu i ngā akitu o nga mātātuhī i muri i ngā panoni.**

## Te Tauanga

Ngā Whāinga		
Ka whakaoti rapanga te ākonga, ka whakamārama otinga, e whai wāhi mai ana:	He tauira ēnei o ngā āhuratanga me mātua mōhio te ākonga e tutuki ai tana whakaoti rapanga:	
<ul style="list-style-type: none"> <li>te raraunga whakarōpū matatini<sup>18</sup></li> <li>te arotake i te whaihua o ngā momo whakaari raraunga<sup>21</sup>.</li> </ul>	<ul style="list-style-type: none"> <li>te whakaatu raraunga ki te kauwhata rautō<sup>19</sup> me te kauwhata porowhita<sup>20</sup></li> <li>ngā tikanga matatika<sup>22</sup> e hāngai ana, (pērā i te tikanga kia noho matatapu<sup>23</sup> ngā kaiwhakautu pātai o tētahi tūhuratanga tauanga).</li> </ul>	<p><sup>18</sup>multivariate category data</p> <p><sup>19</sup>stem-and-leaf graph</p> <p><sup>20</sup>pie graph</p> <p><sup>21</sup>data display</p> <p><sup>22</sup>ethical conventions</p> <p><sup>23</sup>anonymous</p>

## Te Reo Matatini o te Pāngarau

Hei tauira kupu		
<ul style="list-style-type: none"> <li>kauwhata rautō</li> <li>tāpaetanga kōrero</li> <li>kauwhata porowhita</li> </ul>	<ul style="list-style-type: none"> <li>rāpoi</li> <li>manei</li> <li>mōwaho</li> </ul>	<ul style="list-style-type: none"> <li>āhuratanga kōhure</li> </ul>
Hei tauira whakaahuahanga		
<ul style="list-style-type: none"> <li>kauwhata rautō</li> </ul>	<ul style="list-style-type: none"> <li>kauwhata porowhita</li> </ul>	

## He Tauira Rapanga

### Te Tauanga 3e

### Rapanga 12

#### Rauemi: He kāri.

Mā ia ākonga e tuhi tētahi papa raraunga pēnei i te mea kei te taha matau. Kei ia wāhanga o te papa raraunga te whakautu ki ngā pātai nei:

- He tama, he kōtiro rānei koe?
- Ko te ringa mauī, ko te ringa matau rānei tō ringa tuhi?
- Ko koe te mātāmua, te pōtiki, tētahi tamaiti waenganui rānei o tō whānau?
- He mōkai tā tō whānau?

Ka whakakao mai i ngā papa raraunga katoa o te akomanga. Ka whakatakoto tāpaetanga kōrero, pātai rānei hei tūhura mā rātou i ngā raraunga, hei whakaputa whakaari raraunga.

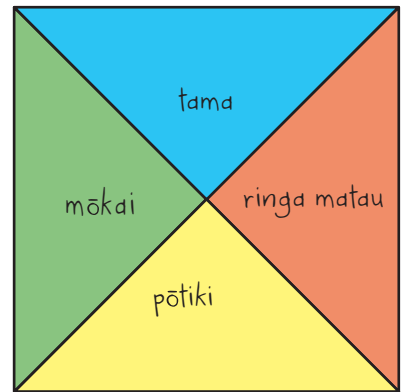

Kia tika te whakatakoto tāpaetanga kōrero, pātai rānei, te tūhura me te wehewehe i ngā raraunga hei whakaputa whakaaro mō aua tāpaetanga kōrero. Hei tauira pātai:

- He aha te hautanga o te hunga ringa mauī me te hunga ringa matau?
- Ka pērā anō ngā hautanga ringa mauī, ringa matau mō ngā tamariki o tētahi atu akomanga?
- He nui ake te hautanga o te hunga kōtiro whiwhi mōkai, he nui ake rānei te hautanga o te hunga tamatāne whiwhi mōkai?
- Kei te hunga mātāmua, kei te hunga pōtiki, kei te hunga o waenganui rānei te kaha kitea o te ringa mauītanga?

Kia tika te whiriwhiri i ngā momo whakaari raraunga e hāngai ana ki te tūhuratanga me te hanga i aua whakaari raraunga.

## Te Tauanga 3e

### Rapanga 13

Koia nei ngā omanga i riro i a Māia rāua ko Horiana i roto i ā rāua kēmu kirikiti tekau:

Māia: {32, 45, 43, 47, 0, 102, 37, 48, 51, 40}

Horiana: {107, 92, 3, 45, 0, 9, 89, 94, 5, 101}

Whakaaturia ngā omanga a te tokorua nei ki tētahi kauwhata rautō hiato. Whakamāramahia ētahi kōrero e kitea mai ana i te kauwhata.

**Kia tika te whakaatu i ngā raraunga ki tētahi kauwhata rautō hiato.**

**Kia tika te whakamārama i ētahi āhuatanga e kitea ana i te kauwhata.**

**Hei tauira:**

- I ia kēmu, he āhua rite tonu ngā omanga a Māia, kāore e tino piki e tino heke rānei ana omanga. E 2 ngā kēmu kāore i whai i tēnei āhuatanga, arā, i tētahi kēmu karekau ana omanga, i tētahi 102 ana omanga. He raraunga mōwaho ēnei.
- Ka tino piki heke, piki heke ngā omanga a Horiana. He pai i ētahi kēmu, he koretake i ētahi. He raraunga manei.

			2	10	1, 7	
				9	2, 4	
				8	9	
				7		
				6		
			1	5		
8, 7, 5,	3, 0		4	5		
	7, 2		3			
			2			
			1			
		0	0	0, 3, 5, 9		
			Māia	Horiana		

## Te Tauanga 3e

### Rapanga 14

**Rauemi:** He rorohiko me tētahi hōtaka ripanga.

He tūtohi tēnei e whakaatu ana i te momo hua rākau matareka ki ngā tamariki o tētahi akomanga:

Te hua rākau	panana	āporo	ārani	huakiwi	pea	pītiti
Te tokomaha o ngā ākonga	3	6	4	2	4	5

- Tokohia katoa ngā tamariki o tēnei akomanga?
- Whakaurua ngā momo hua rākau me te maha o ngā tamariki ki te hōtaka ripanga i te rorohiko.
- Whakaaturia ngā raraunga ki te kauwhata pou, ki te kauwhata porowhita hoki.
- Tirohia ngā kauwhata e 2, ka whakautu ai i ngā pātai:
  - ◇ Tokohia ngā tamariki i kī ai ko te pītiti tā rātou hua rākau matareka?
  - ◇ Ko tēhea o ngā kauwhata i tirohia e koe hei whakautu i tērā pātai?
  - ◇ He aha i tika ai tēnā kauwhata hei whakautu i taua pātai?
  - ◇ Ko tēhea te hua rākau matareka o te hauwhā o ngā tamariki?
  - ◇ Ko tēhea o ngā kauwhata i tirohia e koe hei whakautu i tērā pātai?
  - ◇ He aha i tika ai tēnā kauwhata hei whakautu i taua pātai?

**Kia tika te whakauru i ngā raraunga ki te ripanga rorohiko, me te whakaputa i ngā kauwhata e rua.**

**Kia mārama ki te tikanga o te kauwhata pou hei whakaatu rahinga, me te tikanga o te kauwhata porowhita hei whakaatu hautanga.**

## Te Tūponotanga

Ngā Whāinga		
Ka whakaoti rapanga te ākonga, ka whakamārama otinga, e whai wāhi mai ana:	He tauira ēnei o ngā āhuatanga me mātua mōhio te ākonga e tutuki ai tana whakaoti rapanga:	
<ul style="list-style-type: none"> <li>te reo me ngā whakaahuahanga<sup>24</sup> whānui hei whakaatu tūponotanga.</li> </ul>	<ul style="list-style-type: none"> <li>te whakamahi rārangi hautau<sup>25</sup> hei whakaatu tūponotanga</li> <li>te hoahoa rākau<sup>26</sup> hei whakaatu i ngā putanga<sup>27</sup> o ētahi pāpono raupapa<sup>28</sup>.</li> </ul>	<p><sup>24</sup>representation  <sup>25</sup>fraction line  <sup>26</sup>tree diagram  <sup>27</sup>outcome  <sup>28</sup>combined event</p>

## Te Reo Matatini o te Pāngarau

Hei tauira kupu		
<ul style="list-style-type: none"> <li>tūponotanga</li> <li>putanga</li> </ul>	<ul style="list-style-type: none"> <li>āwhata</li> <li>pāpono raupapa</li> </ul>	<ul style="list-style-type: none"> <li>pāpono</li> <li>hoahoa rākau</li> </ul>
Hei tauira whakaahuahanga		
<ul style="list-style-type: none"> <li>hoahoa rākau</li> </ul>	<ul style="list-style-type: none"> <li>rārangi hautau</li> </ul>	

## He Tauira Rapanga

### Te Tūponotanga 3e

### Rapanga 15

Tokotoru ngā tamariki a Hone rāua ko Mihipeka. Kāore koe i te mōhio mēnā he tāne, he wahine rānei ā rāua tamariki. Tuhia he hoahoa rākau hei whakaatu i ngā raupapatanga e taea ana mō te tama me te tamāhine.

- He aha te tūponotanga he tama katoa ā rāua tamariki?
- He aha te tūponotanga he tamāhine te mātāmua?
- He aha te tūponotanga e rua ngā tamāhine?
- He aha te tūponotanga e rua ngā tamāhine, ā, he tamāhine te pōtiki?

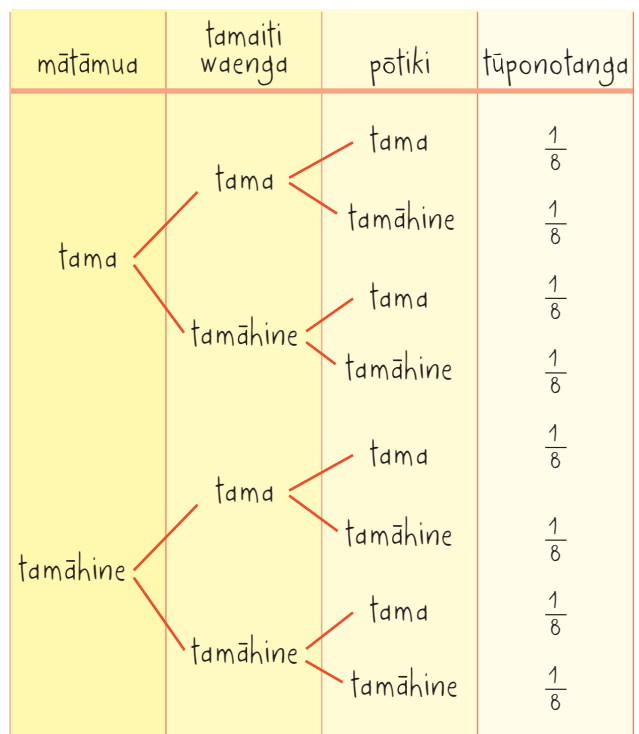

Kia tika te tuhi hoahoa rākau me te whiriwhiri i ngā tūponotanga. Arā:

- $\frac{1}{8}$  te tūponotanga he tama katoa ā rāua tamariki.
- $\frac{1}{2}$  te tūponotanga he tamāhine te mātāmua.
- $\frac{3}{8}$  te tūponotanga e rua ngā tamāhine.
- $\frac{1}{4}$  te tūponotanga e rua ngā tamāhine, ā, he tamāhine te pōtiki.



## Te Tau: Te Mātauranga Tau me ngā Rautaki Tau

(TPT) Kaupae 7

Ngā Whāinga		
Ka whakaoti rapanga te ākonga, ka whakamārama otinga, e whai wāhi mai ana:	He tauira ēnei o ngā āhuatanga me mātua mōhio te ākonga e tutuki ai tana whakaoti rapanga:	
<ul style="list-style-type: none"> <li>ngā rautaki whakarea<sup>1</sup> whānui mō te whiriwhiri ōrau, ōwehenga<sup>2</sup> māmā hoki hei whakaatu pānga rahinga<sup>4</sup>.</li> </ul>	<ul style="list-style-type: none"> <li>ngā tauoti me ngā tau hautanga, me te mātauranga uara tū<sup>3</sup> e hāngai ana</li> <li>ngā tikanga me te whakamahinga o te tau tōrarō<sup>5</sup></li> <li>te whakaawhiwhi<sup>6</sup> tauoti, tau ā-ira hoki</li> <li>ngā hautau ōrite (hautau, hautanga ā-ira, ōrau)</li> <li>ngā tauwehe<sup>7</sup> me ngā taurea<sup>8</sup> o tētahi tau</li> <li>ngā ōrau nui ake i te 100%.</li> </ul>	<p><sup>1</sup>multiplicative strategy</p> <p><sup>2</sup>ratio</p> <p><sup>3</sup>place value</p> <p><sup>4</sup>quantitative relationship</p> <p><sup>5</sup>negative number</p> <p><sup>6</sup>round</p> <p><sup>7</sup>factor</p> <p><sup>8</sup>multiple</p>

## Te Reo Matatini o te Pāngarau

Hei tauira kupu		
<ul style="list-style-type: none"> <li>ōwehenga</li> <li>tau tōrarō</li> <li>tau pātata</li> <li>taurea</li> </ul>	<ul style="list-style-type: none"> <li>hautanga</li> <li>rārangi tau</li> <li>ōrau</li> <li>tauwehe</li> </ul>	<ul style="list-style-type: none"> <li>wāwāhi tau</li> <li>whakaawhiwhi</li> <li>hautau ā-ira</li> <li>whakatau tata</li> </ul>
Hei tauira tohu		
<ul style="list-style-type: none"> <li>% (tohu ōrau)</li> </ul>	<ul style="list-style-type: none"> <li>: (tohu ōwehenga)</li> </ul>	<ul style="list-style-type: none"> <li>/ (tohu pāpātanga)</li> </ul>
Hei tauira whakaahuahanga		
<ul style="list-style-type: none"> <li>he rārangi tau matarua</li> </ul>		

## He Tauira Rapanga

Te Tau 4a

### Rapanga 1

Tokotoru ngā kaikato āporo. E 68.46 kg āporo i katohia e tētahi, e 74.32 kg i katohia e te tuarua, e 65.50 kg i katohia e te tuatoru o rātou.

- Hui katoa, he aha tō whakatau tata i te taumaha o ngā āporo a te tokotoru nei?
- He nui ake te taumaha āporo a te tokotoru nei i tāu i whakatau tata ai, he iti iho rānei? He aha ai?

Kia tika te whakamārama i te whakaawhiwhinga o ngā tau katoa ki te 70, te 10 kg e pātata ana. He māmā te whakarea i te 70 ki te 3, ka 210 kg.

He iti iho te taumaha āporo i katohia e te tokotoru nei i te whakataunga tata, arā, i te 210 kg. Hei whakamārama: Kei runga ake i te 70 kg te kaikato tuarua, e 4.32 kg te nui ake, engari he nui ake i te 4.32 kg te itinga iho i te 70 kg ngā āporo a te kaikato tuatahi me te tuatoru.



# WHANAKETANGA 4a

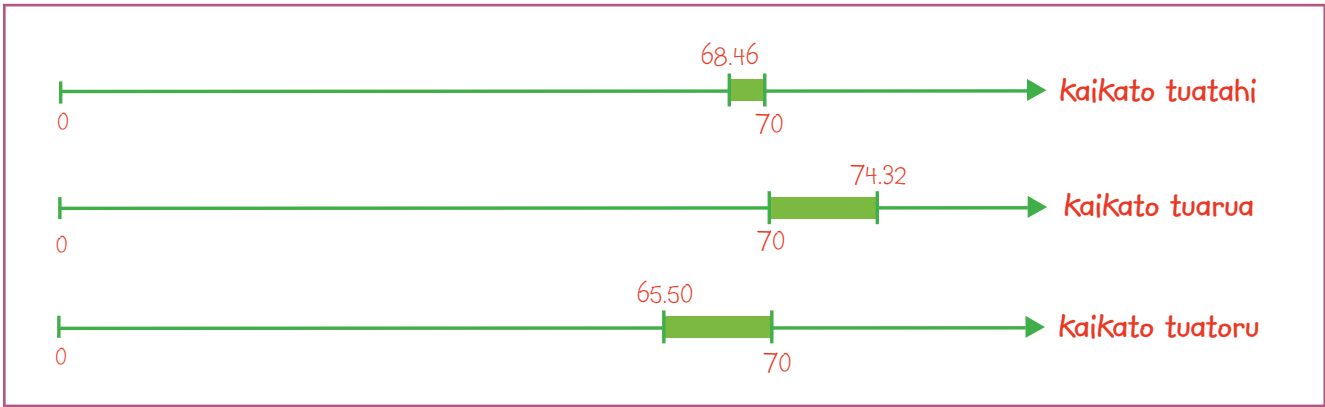

## Te Tau 4a

### Rapanga 2

E  $6.5^\circ$  te paemahana i Taupō i te 9:00 i te ata i tētahi rā. E  $9^\circ$  te mātao ake i Ōtepoti. E hia te paemahana i Ōtepoti?



Kia tika te otinga ( $-2.5^\circ$ ) me te whakamārama i tētahi wāwāhi tau e whaihua ana, pēnei i tēnei:



$$\begin{aligned}
 6.5 - 9 &= 6.5 - 6.5 - 2.5 \\
 &= 0 - 2.5 \\
 &= -2.5
 \end{aligned}$$

rautaki

Ka tango i te 6.5 i te tuatahi, ka  $0^\circ$ . E 2.5 atu anō hei tango atu, kia tangohia te katoa o te  $9^\circ$ . Ka tae atu ki te  $-2.5^\circ$ .

## Te Tau 4a

### Rapanga 3

$\$10,000$  te moni a tētahi rōpū, i whakaurua ki tētahi pūtea pēke mō te kotahi tau. I roto i taua wā, ka piki te uara (wāriu) ki te 115% o te  $\$10,000$ . E hia te rahi o tā rātou pūtea i te paunga o te tau?

Kia tika te otinga ( $\$11,500$ ) me te whakamārama i tētahi rautaki wāwāhi tau e whaihua ana, pēnei i tēnei:



$$\begin{aligned}
 100\% \text{ o te } 10\,000 &= 10\,000 \\
 15\% \text{ o te } 10\,000 &= 1\,500 \\
 \hline
 115\% \text{ o te } 10\,000 &= 11\,500
 \end{aligned}$$



Ko te 100% o te  $\$10,000$ , koia ko te  $\$10,000$ . Ko te  $\$1,500$  te 15% o te  $\$10,000$ . Hui katoa ēnā, ko te  $\$11,500$ .

# WHANAKETANGA 4a

Te Tau 4a

## Rapanga 4

E 49 kg āporo, ka wehea ki ētahi pēke e toru, kia ōrite te taumaha o ia pēke.  
E hia manokaramu (kg) āporo kei ia pēke?

Kia tika te otinga ( $16\frac{1}{3}$ ), me te whakamārama i tētahi rautaki wāwāhi tau e whaihua ana, pēnei i ēnei:

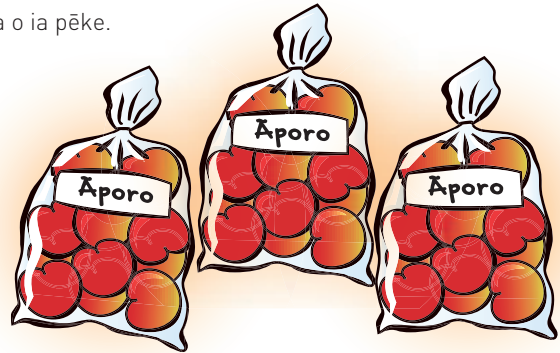

48						1
8	8	8	8	8	8	
16		16		16		

Ka wāwāhia te 49 ki te 48 me te 1. E mōhiotia ana, ina whakawehea te 48 ki te 6, ka 8. Nō reira ki te whakawehea te 48 ki te 3, ka 16 tērā, nā te mea ko te 3 te haurua o te 6, me whakarearua te 8, ka 16. Whakawehea te kotahi ki te 3, ka kotahi hautoru tēnā ( $\frac{1}{3}$ ). Hui katoa, ko te  $16\frac{1}{3}$  kg āporo kei ia pēke.

2

$$\begin{aligned}
 49 \div 3 &= (30 \div 3) + (19 \div 3) \\
 &= 10 + 6\frac{1}{3} \\
 &= 16\frac{1}{3}
 \end{aligned}$$

Ka wāwāhia te 49 ki ētahi wāhanga māmā te whakawehe ki te 3. Arā, ko te 30 me te 19. Ka whakawehea te 30 ki te 3, ka 10. Ka whakawehea te 19 ki te 3, ka  $6\frac{1}{3}$ . Hui katoa ko te  $16\frac{1}{3}$  tērā.

Te Tau 4a

## Rapanga 5

E 43 ngā whakautu tika a Roimata o ngā pātai 50 i tētahi whakamātautau.  
17 ngā whakautu tika a Hana o ngā pātai 20 i tāna whakamātautau. I riro i a wai te māka pai rawa atu o ēnei tokorua?

Kia tika te otinga (Roimata) me te whakamārama i tētahi rautaki hei whakatairite hautanga. Hei taurira:

**He Whakamātautau Pāngarau**

Te Rā: 16/08/2010

Ingoa: Roimata

- E 60 ngā pātai mō te raihana taraiwa motukā, e 48 ngā whakautu a Pita i tika. He aha te ōrau o ana pātai tika?
- E \$6.00 te utu mō ngā poukena e 8. E hia ngā poukena ka taea te hoko mō te \$15.00?
- E 81 ngā pōro tēnehi e hokona ana e Māka. E 3 ngā pōro kei ia kēne. E hia ngā kēne ka hokona e ia?
- E 8 ngā paepae hēki hei kai mā te manuhiri i te marae. 48 ngā hēki kei ia paepae. E hia katoa ngā hēki?

**He Whakamātautau Pāngarau**

Te Rā: 16/08/2010

Ingoa: Hana

- He horoi motukā te mahi a Anikiwa. Ka pau te 6 hāora ki te horoi i ngā motukā 14, he ōrite te roa mō ia motukā. E hia hāora hei horoi i ētahi motukā 21?
- E 36 ngā kēne kei roto i te pouaka kotahi. E hia ngā kēne kei roto i ētahi pouaka e 5?
- Tokowhā ngā tāngata kei roto i tētahi rōpū e kato hua rākau ana. \$108 te utu ka hoatu ki te rōpū. E hia te utu mā ia tangata o te rōpū?
- Kei te penapena moni a Meihana. 16 ngā wiki mō te penapena i te \$40. E hia ngā moni penapena i te paunga o ētahi wiki e 6?

$$\frac{43}{50} \xrightarrow{\times 2} \frac{86}{100}$$

$$\frac{17}{20} \xrightarrow{\times 5} \frac{85}{100}$$

Ka hurihia ngā māka hei ōrau. He ōrite te 43 o roto i te 50 ki te 86 o roto i te 100 [mā te whakarea ki te 2]. He ōrite te 17 o roto i te 20 ki te 85 o roto i te 100 [mā te whakarea ki te 5]. E 86% te māka a Roimata, e 85% te māka a Hana.

## Te Taura me te Pānga

Ngā Whāinga		
Ka whakaoti rapanga te ākonga, ka whakamārama otinga, e whai wāhi mai ana:	He taura ēnei o ngā āhuatanga me mātua mōhio te ākonga e tutuki ai tana whakaoti rapanga:	
<ul style="list-style-type: none"> <li>te whakaatu pānga māmā hei whārite taurangi?, hei kauwhata anō hoki.</li> </ul>	<ul style="list-style-type: none"> <li>te hua o te huri i tētahi taurangi, me te pānga ki taurangi kē.</li> </ul>	<i>?algebraic equation</i>

## Te Reo Matatini o te Pāngarau

Hei taura kupu		
<ul style="list-style-type: none"> <li>huinga takirua raupapa</li> <li>tuaka pae, tuaka pou, tuaka-x, tuaka-y</li> <li>taurangi</li> </ul>	<ul style="list-style-type: none"> <li>whārite</li> <li>pānga</li> </ul>	<ul style="list-style-type: none"> <li>kauwhata rārangi</li> <li>taura</li> </ul>
Hei taura whakaahuahanga		
<ul style="list-style-type: none"> <li>he kauwhata rārangi</li> <li>he whārite whai taurangi</li> </ul>	<ul style="list-style-type: none"> <li>he huinga takirua raupapa</li> </ul>	<ul style="list-style-type: none"> <li>he tūtohi</li> </ul>

## He Taura Rapanga

### Te Taura me te Pānga 4a

### Rapanga 6

1. Ka tonoa a Hinerangi ki te hoko miraka, parāoa hoki mā tōna whānau. Ka meatia kia 3 ngā miraka, kia 2 ngā parāoa.

a. Ko tēhea whārite te mea tika hei tātai i te tapeke o te utu? ( $u$  = te utu tapeke,  $m$  = te utu mō te miraka kotahi,  $p$  = te utu mō te parāoa kotahi). He aha koe i whiriwhiri ai ko tēnā te whārite e tika ana?

$$2(3m + p) = u$$

$$3p + 2m = u$$

$$2p + 3m = u$$

e. Mēnā e \$2.50 te utu mō te miraka kotahi, \$1.30 mō tētahi parāoa, e hia te tapeke o te utu?

Kia tika te whiriwhiri i te whārite, me te whakamārama anō. Arā, mēnā ko te  $p$  hei tohu i te utu mō te parāoa kotahi, me whakarea ki te 2 hei tātai i te utu mō ngā parāoa e rua, ko te  $2p$  tērā. Mēnā ko te  $m$  hei tohu i te utu mō te miraka kotahi, me whakarea tēnā ki te 3 hei tātai i te utu mō ngā miraka e 3, arā, ko te  $3m$  tērā. Hui katoa, ko te  $2p + 3m$  te whārite hei tātai i te tapeke o te utu.

Kia tika hoki te whakauru i ngā utu ki te whārite me te tātai i te utu tapeke (\$10.10). Arā:

$$2p + 3m = u$$

$$(2 \times \$1.30) + (3 \times \$2.50) = u$$

$$\$2.60 + \$7.50 = u$$

$$\$10.10 = u$$

## Te Taura me te Pānga 4a

## Rapanga 7

Koia nei te whārite e hono ana i te maha o ngā hāora mahi a Rona me te utu ka riro i a ia:

$$U = 15 \times h$$

1. E tohu ana te  $U$  me te  $h$  i te aha?
2. E hia te utu ā-hāora ka riro i a Rona?
3. Whakaaturia ki tētahi tūtohi te utu ka riro i a Rona mēnā, e 2, e 3, e 4, e 5 ana hāora mahi.
4. E hia te utu ka riro i a Rona mēnā e 20 ana hāora mahi i tētahi wiki?
5. Ka riro i a Rona te \$120 mō āna mahi i tētahi wiki. E hia ana hāora mahi i taua wiki?
6. Whakaaturia ngā hāora mahi (0 ki te 6) me te utu ka riro i a Rona ki tētahi kauwhata rārangi.

Kia tika ngā whakautu me te whakaatu anō i te mōhio ki:

- te whakamāori whārite i runga i te horopaki o taua whārite
- te whakaatu pānga ki te tūtohi
- te whakamahi whārite hei tātai i tētahi o ngā taurangi o taua whārite
- te whakaatu pānga ki te kauwhata rārangi.

## Te Ine me te Hanga

Ngā Whāinga		
Ka whakaoti rapanga te ākonga, ka whakamārama otinga, e whai wāhi mai ana:	He tauira ēnei o ngā āhuetanga me mātua mōhio te ākonga e tutuki ai tana whakaoti rapanga:	
<ul style="list-style-type: none"> <li>te whakawhitiwhiti waeine</li> <li>ngā inenga tapa me ngā ture hei tātai paenga<sup>10</sup>, horahanga, rōrahi hoki o ngā āhua māmā</li> <li>te pāpātanga<sup>14</sup> hei ine i tētahi mea (pēnei i te km/h hei ine i te tere)</li> <li>te whakaatu āhua ahu-3<sup>15</sup> hei hoahoa ahu-2 (pērā i te tuhinga hoahoa inerite<sup>16</sup>)</li> <li>te tuhi hoahoa āwhata.</li> </ul>	<ul style="list-style-type: none"> <li>ngā momo tirohanga ki tētahi mea, pērā i te tirohanga ā-manu, te tirohanga mua me te tirohanga mauī.</li> <li>te whakamahinga o te ōwehenga<sup>11</sup> me te taurahi<sup>12</sup> hei tuhi hoahoa āwhata<sup>13</sup>.</li> </ul>	<p><sup>10</sup>perimeter</p> <p><sup>11</sup>ratio</p> <p><sup>12</sup>scale factor</p> <p><sup>13</sup>scale diagram</p> <p><sup>14</sup>rate</p> <p><sup>15</sup>3-dimensional</p> <p><sup>16</sup>isometric diagram</p>

## Te Reo Matatini o te Pāngarau

Hei tauira kupu		
<ul style="list-style-type: none"> <li>ture tātai</li> <li>rōrahi</li> <li>hoahoa āwhata</li> </ul>	<ul style="list-style-type: none"> <li>paenga</li> <li>ahu-2, ahu-3</li> <li>tirohanga ā-manu, tirohanga mua, tirohanga mauī...</li> </ul>	<ul style="list-style-type: none"> <li>horahanga</li> <li>taurahi</li> <li>pāpātanga</li> </ul>
Hei tauira whakaahuahanga		
<ul style="list-style-type: none"> <li>he hoahoa inerite</li> </ul>	<ul style="list-style-type: none"> <li>ngā momo tirohanga</li> </ul>	<ul style="list-style-type: none"> <li>he hoahoa āwhata</li> </ul>

## He Tauira Rapanga

Te Ine me te Hanga 4a

### Rapanga 8

E 20 rita te rōrahi o tētahi pēke wairākau.



- Tuhia he hoahoa o tētahi pouaka e taea ai te katoa o te wairākau o tētahi pēke te ringi atu ki roto. He pēhea nei te roa, te whānui, me te teitei o te pouaka?
- Hauruatia ia taha o tō pouaka. E hia ngā rita wairākau ka taea ki roto ināianei?

- Kia tika te tuhi hoahoa o te pouaka me te whakamārama i ngā roa o ngā tapa o te pouaka. Ka mōhio i te ōrite o te 1 L me te 1 000 cm<sup>3</sup>. Nō reira, e tika ana kia 20 000 cm<sup>3</sup> te rōrahi o te pouaka.

Ka whakamahia te ture tātai  $R = r \times wh \times t$  ( $R =$  rōrahi,  $r =$  roa,  $wh =$  whānui,  $t =$  teitei) mō te rōrahi o tētahi poro tapawhā hāngai, ā, ka whiriwhiria ngā tapa e toru. Ina whakareatia aua tapa e toru, ka rite ki te 20 000. Hei tauira:

$$20 \text{ cm} \times 50 \text{ cm} \times 20 \text{ cm} (20 \times 50 \times 20 = 20\,000)$$

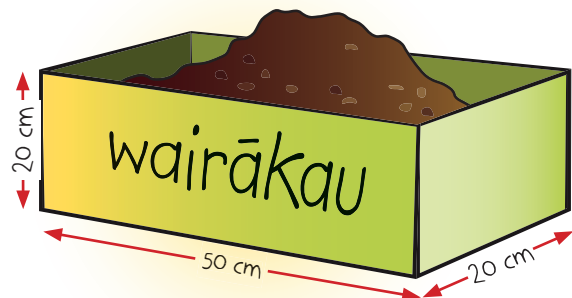

- Kia tika te whakamahi i te ture hei tātai i te rōrahi o tētahi pouaka, arā:

$$R = r \times wh \times t$$

$$= 25 \times 10 \times 10 \text{ (te haurua o ngā inenga o te pouaka kei runga ake nei)}$$

$$= 2\,500 \text{ cm}^3$$

$$= 2.5 \text{ L (rita) wairākāu ka taea ki roto}$$

## Te Ine me te Hanga 4a

### Rapanga 9

Tāngia he hoahoa āwhata o tētahi papa tākaro tēnehi, poitarawhiti rānei. Whakaaturia ngā paetaha/rārangi katoa o te papa ki tō hoahoa āwhata. He aha te taurahi o tō hoahoa? Whakamāramatia mai ō mahi katoa.

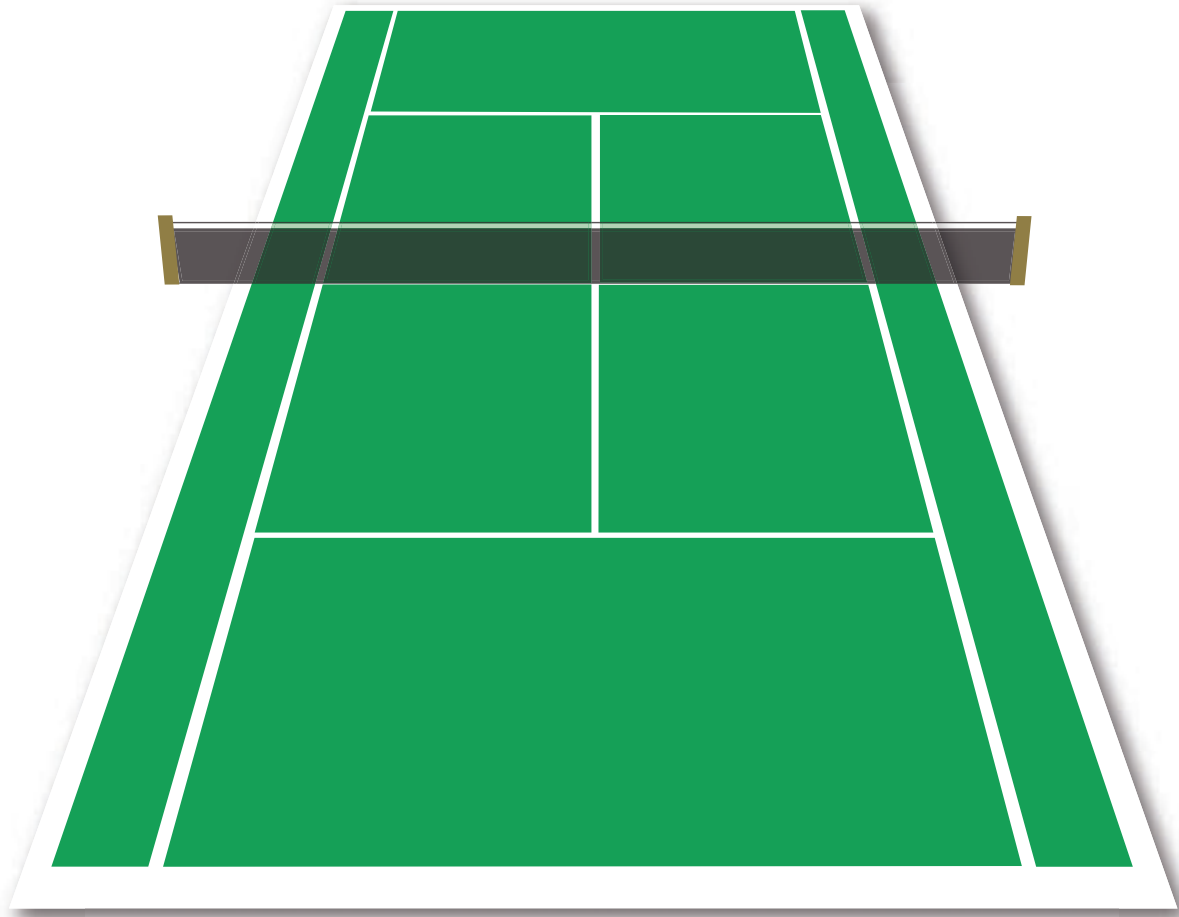

Kia tika te tuhi hoahoa āwhata o te papa tākaro me te whai i tētahi raupapatanga mahi pēnei i tēnei:

- Ka tuhi ā-ringatia te papa tākaro me ōna paetaha/rārangi katoa.
- Ka inea te roa o ngā rārangi, me te tuhi anō i ēnei inenga ki te hoahoa. Kia tika te whiriwhiri me te whakamahi i te taputapu ine.
- Ka whiriwhiria te taurahi. Ka whakaarohia te rārangi roa rawa o te papa tākaro me te roa o tēnei rārangi i te hoahoa. Hei tauira, mēnā e 30 m te tapa roa o te papa tākaro, ka hurihia tēnei hei mitarau i te tuatahi (30 m → 30 cm), kātahi ka hauruatia (30 cm → 15 cm). E pai ana te 15 cm hei rārangi roa rawa ki te hoahoa.
- Kia pērātia anō ngā inenga katoa hei whiriwhiri i te roa o ngā rārangi ki te hoahoa.
- Ka whakamahia te rūri hei tuhi i te hoahoa āwhata, me te tika anō o te roa o ngā rārangi o te hoahoa.

## Te Ine me te Hanga 4a

### Rapanga 10

**Rauemi:** he mataono rite  $1 \text{ cm}^3$

Hoatu kia 8 pea ngā mataono rite ( $1 \text{ cm}^3$ ) ki ngā ākonga, ka tono i a rātou kia hangaia tētahi āhua. Me whakamahi te katoa o ngā mataono rite, ā, kia noho hāngai tonu te mata o tētahi ki te mata o te mea e piritahi ana (arā, kia kaua e inaki ngā mata). Hei tauira hanganga:

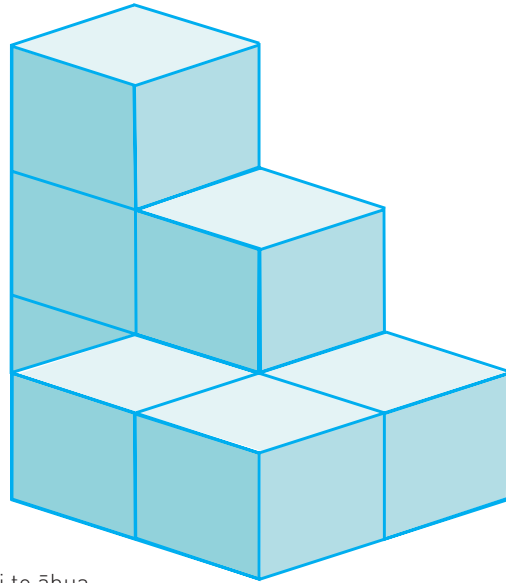

1. Tuhia ēnei tirohanga ki te hanganga:

- tirohanga runga
- tirohanga mua
- tirohanga mauī
- tirohanga matau.

2. Hoatu ngā tuhinga o ngā tirohanga ki tētahi hoa hei hanga māna i te āhua.

**Kia tika te mahi a te ākonga hei whakaatu i tana mōhio ki ngā momo tirohanga ki tētahi āhua. Kia āhei anō ki te whakamāori i ngā momo tirohanga hei hanga i te āhua e whakaaturia ana.**

## Te Ine me te Hanga 4a

### Rapanga 11

Inea te tere e oti ai i tētahi hoa te 100 mita mā raro. E hia manomita i te hāora (km/h) te tere o tana hīkoi?

**Kia tika te whakatutuki i ngā mahi nei:**

- Ka whakamahi wati (wati tū rānei) hei ine i te wā o tētahi hoa ki te hīkoi i te 100 mita. (Ākene pea me ine hoki te 100 mita, mēnā karekau he papa omaoma i te rohe o te kura.)
- Ka hurihia tēnei inenga hei manomita i te hāora (km/h).

Hei tauira, 100 mita i te 45 hākona:

- Whakareatia ki te 4:  
400 mita i te 3 meneti (45 hākona [ $\frac{3}{4}$  meneti] x 4 = 3 meneti).
- Whakareatia ki te 20:  
8 000 mita i te hāora (3 meneti x 20 = 60 meneti = 1 hāora).
- Hurihia ngā mita hei manomita:  
8 km/h.

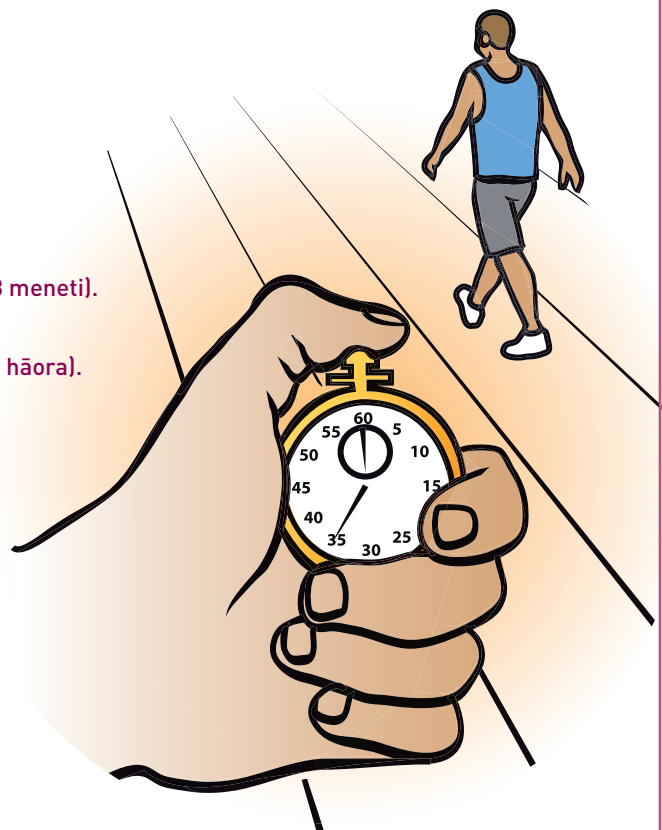



# WHANAKETANGA 4a

## Te Wāhi, te Ahunga, me te Panoni

Ngā Whāinga		
Ka whakaoti rapanga te ākonga, ka whakamārama otinga, e whai wāhi mai ana:	He tauira ēnei o ngā āhuetanga me mātua mōhio te ākonga e tutuki ai tana whakaoti rapanga:	
<ul style="list-style-type: none"> <li>ngā koki o te kāpehu<sup>17</sup> hei whakaatu ahunga</li> <li>te hangarite panoni<sup>18</sup> o tētahi āhua.</li> </ul>	<ul style="list-style-type: none"> <li>te hononga o ngā koki ki ngā ahunga matua o te kāpehu</li> <li>ngā tikanga o te hangarite rārangi<sup>19</sup> me te hangarite hurihanga<sup>20</sup> o tētahi āhua.</li> </ul>	<sup>17</sup> compass <sup>18</sup> transformation symmetry <sup>19</sup> line symmetry <sup>20</sup> rotational symmetry

## Te Reo Matatini o te Pāngarau

Hei tauira kupu		
<ul style="list-style-type: none"> <li>hangarite</li> <li>putu/tākiri</li> <li>mātātuhi</li> </ul>	<ul style="list-style-type: none"> <li>hangarite rārangi</li> <li>kāpehu</li> <li>mātāoroko</li> </ul>	<ul style="list-style-type: none"> <li>hangarite hurihanga</li> <li>koki</li> </ul>
Hei tauira whakaahuahanga		
<ul style="list-style-type: none"> <li>ngā momo mahere</li> </ul>	<ul style="list-style-type: none"> <li>he kāpehu</li> </ul>	

## He Tauira Rapanga

Te Wāhi, te Ahunga, me te Panoni 4a

### Rapanga 12

Titiro ki te mahere o Aotearoa, te tai rāwhiti o Ahitereiria, me tētahi wāhanga o Te Moana-nui-a-Kiwa. Whakamahia tō ine-koki, ka whakautu ai i ngā pātai.



- E hia tākiri te ahunga atu i Tāmakimakaurau ki Piripane?
- E hia tākiri te ahunga atu i Ōtautahi ki Rarotonga?
- Ka rere atu a Manu i Poihākena, e 075° te ahunga o te waka rererangi. E haere ana ia ki hea?
- Atu i Nadi, 190° te ahunga o te haere. E haere ana ki hea?
- Mai i Rarotonga ki Tāmakimakaurau, e hia putu te ahunga?
- Ki te titiro a ō karu, he aha te ahunga atu i Ōtautahi ki Hobart?

Kia tika te whakamahi ine-koki hei ine i ngā ahunga nei, me te mōhio ka inea whakatekaraka ngā ahunga mahere, mai i te raki. Kia tika hoki te whakatau tata i te 270°, te ahunga atu i Ōtautahi ki Hobart, me tētahi whakamārama e hāngai ana. Hei tauira, ina huri whakatekaraka mai i te raki, e toru ngā koki hāngai kia ahu atu ki Hobart.

Te Wāhi, te Ahunga, me te Panoni 4a

## Rapanga 13

He tapawhā whakarara tēnei me tētahi taitapa he ōrite te āhua me te rahi ki tō te tapawhā whakarara:

Tapawhā Whakarara

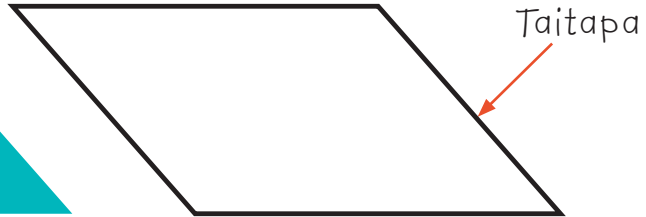

I roto i te hurihanga kotahi, e rua ngā taunga o te tapawhā whakarara ki tōna taitapa, arā, ko ēnei:

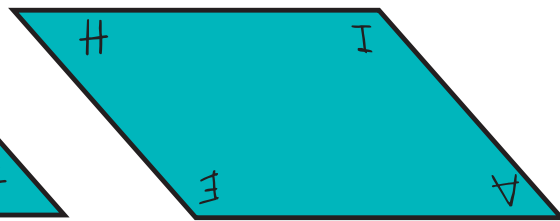
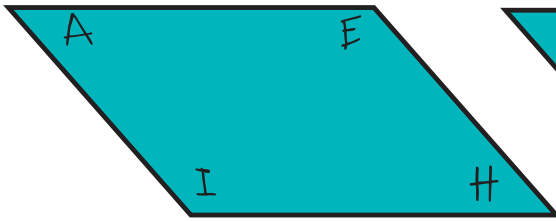

1. Tuhia ētahi āhua, ka toru ngā taunga ki tōna taitapa i roto i te hurihanga kotahi (he ōrite te āhua o te taitapa me te āhua).
2. Tuhia ētahi āhua, ka whā ngā taunga ki tōna taitapa i roto i te hurihanga kotahi (he ōrite te āhua o te taitapa me te āhua).
3. Tuhia ētahi āhua, ka ono ngā taunga ki tōna taitapa i roto i te hurihanga kotahi (he ōrite te āhua o te taitapa me te āhua).

**Ka tuhia ngā āhua tika (tapatoru rite, tapawhā rite/tapawhā whakarara rite rānei, tapano rite), me te whakamārama i te hangarite hurihanga o tēnā me tēnā o ngā āhua. Hei tauira:**

1. E toru ngā hangarite hurihanga:



2. E whā ngā hangarite hurihanga:

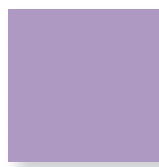

3. E ono ngā hangarite hurihanga:



## Te Tauanga

Ngā Whāinga		
Ka whakaoti rapanga te ākonga, ka whakamārama otinga, e whai wāhi mai ana:	He tauira ēnei o ngā āhuatanga me mātua mōhio te ākonga e tutuki ai tana whakaoti rapanga:	
<ul style="list-style-type: none"> <li>te whakatakoto pātai, <b>tāpaetanga kōrero</b><sup>21</sup> rānei hei tūāpapa mō tētahi tūhuratanga tauanga</li> <li>te whakatairite i te <b>tuari</b><sup>26</sup> o ētahi huinga raraunga</li> <li>te whakamahi <b>wēanga</b><sup>28</sup>.</li> </ul>	<ul style="list-style-type: none"> <li>te tātai toharite<sup>22</sup>, tau waenga<sup>23</sup>, inenga whānui<sup>24</sup>, tau tānui<sup>25</sup> o tētahi huinga raraunga, me te whakaatu ki te whakaari raraunga</li> <li>te whakaatu raraunga ki te <b>kauwhata pou whakaapaapa</b><sup>27</sup></li> <li>te tautohu i ngā <b>taurangi</b><sup>29</sup> o tētahi tūhuratanga tauanga, te kohikohi me te whakaari raraunga mō aua taurangi.</li> </ul>	<p><sup>21</sup>assertion, <sup>22</sup>mean  <sup>23</sup>median  <sup>24</sup>range  <sup>25</sup>mode  <sup>26</sup>distribution  <sup>27</sup>stacked bar graph  <sup>28</sup>measure of central tendency  <sup>29</sup>variable</p>

## Te Reo Matatini o te Pāngarau

Hei tauira kupu		
<ul style="list-style-type: none"> <li>toharite</li> <li>inenga whānui</li> <li>pātengi raraunga</li> </ul>	<ul style="list-style-type: none"> <li>tau waenga</li> <li>tuari raraunga</li> <li>taurangi</li> </ul>	<ul style="list-style-type: none"> <li>tau tānui</li> <li>tāpaetanga kōrero</li> </ul>
Hei tauira whakaahuahanga		
<ul style="list-style-type: none"> <li>he kauwhata pou whakaapaapa</li> </ul>		

## He Tauira Rapanga

### Te Tauanga 4a

### Rapanga 14

Whakahaerehia tētahi tūhuratanga kia kitea ai te roa o te peke a ngā ākonga katoa o tō akomanga.

Tuhia he pūrongo, kia whai wāhi mai ko:

- te whakamārama i te āhua o te kohikohi raraunga
- te whakaari i ngā raraunga ki ngā momo kauwhata e hāngai ana
- te whakaatu i ngā peke a te hunga kōtiro, a te hunga tamatāne, me te katoa o te akomanga, me te peke toharite a tēnā rōpū me tēnā
- te whakaatu i te inenga whānui o ia rōpū raraunga
- te whakaputa kōrero hei whakatairite i te roa o ngā peke a te hunga kōtiro me te hunga tamatāne.

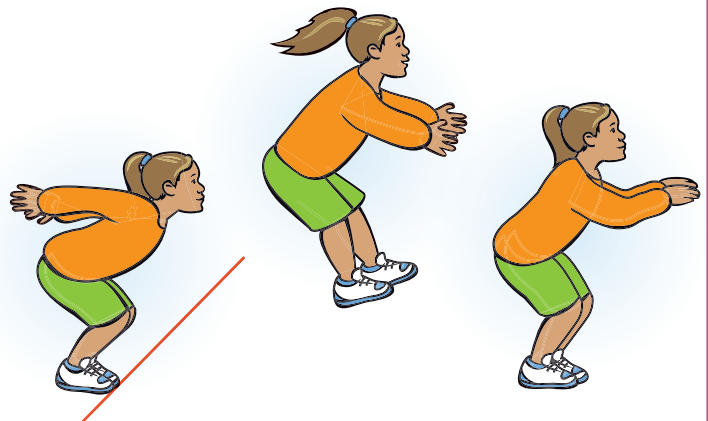

**Kia tika te whakahaere i te tūhuratanga me te whakaputa i te pūrongo:**

- Ākene pea ka meatia kia toru ngā peke mā ia ākonga, ā, ka tātaihia te toharite, koia te roa ka whakaurua ki te huinga raraunga.**
- Kia tika te whiriwhiri i te momo kauwhata e hāngai ana, pērā i te kauwhata pou hiato, te kauwhata rautō hiato rānei, me te whakaatu anō i te toharite a ia rōpū ki te kauwhata.**
- Ka whakaputaina he kōrero e hāngai ana hei whakatairite i te roa o te peke a te hunga kōtiro me te hunga tamatāne.**

## Te Tūponotanga

Ngā Whāinga		
Ka whakaoti rapanga te ākonga, ka whakamārama otinga, e whai wāhi mai ana:	He tauira ēnei o ngā āhuatanga me mātua mōhio te ākonga e tutuki ai tana whakaoti rapanga:	
<ul style="list-style-type: none"> <li>te tōkeke<sup>30</sup>, te haukume<sup>31</sup> rānei o tētahi pāpono tūponotanga<sup>32</sup>.</li> </ul>	<ul style="list-style-type: none"> <li>te whakaatu tūponotanga hei ōrau.</li> </ul>	<sup>30</sup> fairness. <sup>31</sup> bias <sup>32</sup> probability event

## Te Reo Matatini o te Pāngarau

Hei tauira kupu		
• tōkeke	• haukume	• hoahoa rākau
Hei tauira whakaahuhanga		
• he hoahoa rākau		

## He Tauira Rapanga

### Te Tūponotanga 4a

### Rapanga 15

Tērā a Hinemoana rāua ko Matiu e pīrori ana i ētahi mataono tau e rua.

Ka mea atu a Hinemoana, "E hoa, ka whakataetae tāua. Ka pīrorihia ngā mataono e rua, kātahi ka tangohia te tau iti i te tau nui (hei tauira, ki te puta he 4 me te 6, ka tangohia te 4 i te 6, ko te 2 te otinga). Koia nei ngā otinga ka taea: {0, 1, 2, 3, 4, 5}. Mēnā he kore, he kotahi, he rua rānei te otinga, ko au ka toa. Mēnā he toru, he whā, he rima rānei, ko koe tēnā ka toa."

Kei te tōkeke tēnei kēmu a Hinemoana, arā, he ōrite anō te tūponotanga toa o tēnā me tēnā o te tokorua, kei te tītaha rānei? Whakamāramatia mai ō whakaaro.

**Ka tuhia he hoahoa rākau hei tātai i te tūponotanga o ia putanga, kia āta kitea ko te  $\frac{24}{36}$  ( $\frac{2}{3}$ ) te tūponotanga ka puta te 0, te 1, te 2 rānei, ko te  $\frac{12}{36}$  ( $\frac{1}{3}$ ) te tūponotanga ka puta te 3, te 4, te 5 rānei.**



mataono tuatahi    mataono tuarua    putanga

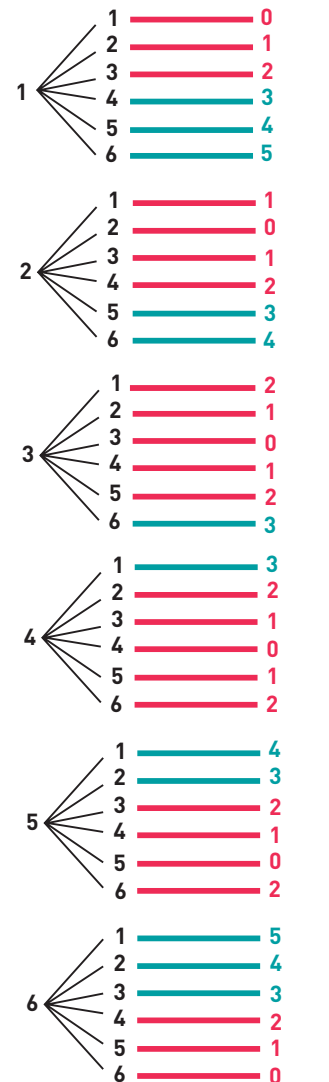

## Te Tau: Te Mātauranga Tau me ngā Rautaki Tau

(TPT) Kaupae 7–8

Ngā Whāinga		
Ka whakaoti rapanga te ākonga, ka whakamārama otinga, e whai wāhi mai ana:	He tauira ēnei o ngā āhuatanga me mātua mōhio te ākonga e tutuki ai tana whakaoti rapanga:	
<ul style="list-style-type: none"> <li>ngā tau tōpū<sup>1</sup> me ngā tau hautanga (hautau noa, hautau ā-ira, ōrau)</li> <li>ngā rautaki tāpiripiri, whakarea hoki, e hāngai ana ki ngā horopaki pānga riterite<sup>5</sup> (pērā i te ōwehenga<sup>7</sup> me te pāpātanga<sup>8</sup> māmā.)</li> </ul>	<ul style="list-style-type: none"> <li>te taupū<sup>2</sup> māmā (pērā i te pūrua<sup>3</sup> me te pūtakerua<sup>4</sup>)</li> <li>te tōtika me te whaitakenga<sup>6</sup> o ngā whakataunga tata me ngā tātaitanga</li> <li>ngā huarahi e tino whaihua ana hei whakaoti tātaitanga i ngā horopaki maha.</li> </ul>	<p><sup>1</sup>integer, <sup>2</sup>exponent  <sup>3</sup>square (power of two)  <sup>4</sup>square root  <sup>5</sup>proportional contexts  <sup>6</sup>reasonableness  <sup>7</sup>ratio  <sup>8</sup>rate</p>

## Te Reo Matatini o te Pāngarau

Hei tauira kupu		
<ul style="list-style-type: none"> <li>tau tōpū</li> <li>pūrua, pūtoru ...</li> <li>ōwehenga</li> </ul>	<ul style="list-style-type: none"> <li>tōraro</li> <li>pūtakerua, pūtaketoru ...</li> <li>pāpātanga</li> </ul>	<ul style="list-style-type: none"> <li>tōrunga</li> <li>taupū</li> </ul>
Hei tauira tohu		
<ul style="list-style-type: none"> <li>: (tohu ōwehenga)</li> <li>+ (tohu tōrunga)</li> </ul>	<ul style="list-style-type: none"> <li>/ (tohu pāpātanga)</li> <li>√</li> </ul>	<ul style="list-style-type: none"> <li>- (tohu tōraro)</li> <li>∛</li> </ul>

## He Tauira Rapanga

### Te Tau 4e

### Rapanga 1

E \$62 te utu mō tētahi pokotaringa (MP3), tāpiri atu ki tērā ko te tāke hokohoko (GST).

- E hia tāra te tāke hokohoko?
- E hia katoa te utu hoko?

Kia mōhio te ākonga ko te 15% te rahi o te tāke hokohoko i Aotearoa.

Kia tika te tātai i ngā otinga (\$9.30, \$71.30), mā tētahi rautaki pēnei:



1

$$10\% \text{ o te } \$62 = \$6.20$$

$$5\% \text{ o te } \$62 = \$3.10$$

---

$$15\% \text{ o te } \$62 = \$9.30$$

Tāpiria te \$9.30 ki te \$62, ka \$71.30

2

- Mā te whakamahi tātaitai. Arā, ka whakareatia te \$62 ki te 1.15, ka \$71.30.

## Te Tau 4e

### Rapanga 2

E 6 ngā kapu ka taea te whakakī i te ipu wai ārani kotahi, 0.125 rita ki ia kapu. E hia rita te rōrahi o te ipu?

Kia tika te otinga (0.75 rita) mā tētahi rautaki pēnei:



- 1 • Ka whakaaturia te rapanga hei whakawehenga, ka huri kōaro hei whakareatanga. Ka whakaaturia te 0.125 ki te rārangi tau, me te whakareatanga ki te 6:

$$\square \div 6 = 0.125 \longleftrightarrow 0.125 \times 6 = \square$$



- 2 • Ka whakaaturia te rapanga hei whakawehenga, ka huri kōaro hei whakareatanga. Ka hurihia te 0.125 hei hautau noa, arā, ko te  $\frac{1}{8}$  ( $0.5 = \frac{1}{2}$ ,  $0.25 = \frac{1}{4}$ ,  $0.125 = \frac{1}{8}$ ). Ka whakareatia te  $\frac{1}{8}$  ki te 6, ka  $\frac{6}{8}$ , arā, ko te  $\frac{3}{4}$ , te 0.75 rānei.

$$\begin{aligned} \square \div 6 = 0.125 &\longleftrightarrow 0.125 \times 6 = \square \\ \frac{1}{8} \times 6 &= \frac{6}{8} \\ &= \frac{3}{4} = 0.75 \end{aligned}$$

- 3 • Ka whakaaturia te rapanga hei whakawehenga. Ka whakamahia te rautaki pānga riterite:
- $3 \div 6 = 0.5$  (Mēnā e 3 rita te ipu, ka 0.5 rita ki ia kapu.)  
 $1.5 \div 6 = 0.25$  (Mēnā 1.5 rita te ipu, ka 0.25 rita ki ia kapu.)  
 $0.75 \div 6 = 0.125$  (Mēnā 0.75 rita te ipu, ka 0.125 rita ki ia kapu.)

## Te Tau 4e

### Rapanga 3

\$123 kei roto i te pūtea pēke a Noema. Mēnā ka tangohia te \$519, e hia te rahi o tana tarepa (tana nama ki te pēke).

Kia tika te otinga (-\$396) mā tētahi rautaki pēnei:

- 1 • He māmā te tango i te 523, ka -400. Engari e 4 te rahinga kē atu o te tango i te 523 i te tango i te 519. Nō reira, me tāpiri anō taua 4:

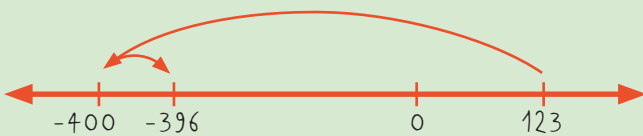

- 2 • Ka hurihia hei tāpiritanga hei whiriwhiri i te huatango o te 519 me te 123. Arā:

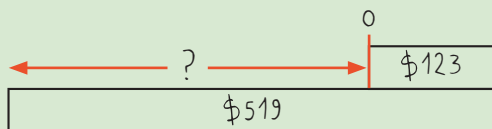

$$123 + \square = 519$$

$$100 + \square = 496 \text{ (Kua tangohia te 23 mai i ia tau)}$$

$$100 + 396 = 496$$

## Te Tau 4e

### Rapanga 4

\$15 te utu mō te 10 kg kūmara. E hia te utu mō te 4 kg?

Kia tika te otinga (\$6.00) mā tētahi rautaki pēnei:

- Ka whiriwhirihia te utu mō te kirokaramu kotahi ( $15 \div 10 = 1.5$ ), kātahi ka whakareatia ki te 4:

kūmara (kg)	utu (\$)
10	15.00
1	1.50
4	6.00

$\div 10$  (from 10 to 1)  
 $\times 4$  (from 1 to 4)  
 $\div 10$  (from 15.00 to 1.50)  
 $\times 4$  (from 1.50 to 6.00)



## Te Tau 4e

### Rapanga 5

E rua ngā tohutaka hei mahi inu wai ārani. Ko tēhea o ngā tohutaka e tino kaha ana te hā o te ārani?

#### Tohutaka 1

Kia 3 ngā kapu wai māori mō ia kapu wai ārani.



wai māori



wai ārani

#### Tohutaka 2

Kia 5 ngā kapu wai māori mō ngā kapu wai ārani e rua.



wai māori

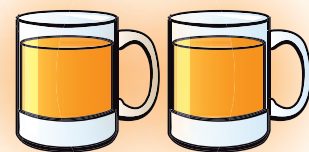

wai ārani

Kia tika te otinga (tohutaka 2) me te whakamārama i tētahi rautaki e whaihua ana, pēnei i tēnei:

- Ka whakareatia te tohutaka 1 ki te 2, ka 6 ngā kapu wai māori, ka 2 ngā kapu wai ārani. Ka rahi ake te rōrahi o te inu, engari ka pūmau tonu te ōwehenga o te wai māori me te wai ārani. Koia nei ngā ōwehenga o ngā inu e rua:
- Tohutaka 1 6:2
- Tohutaka 2 5:2

He ōrite te rōrahi o te wai ārani o ia tohutaka, engari he iti iho te rōrahi o te wai māori i te tohutaka 2. Nō reira koirā te mea e kaha ake ana te hā o te ārani.

## Te Taura me te Pānga

Ngā Whāinga		
Ka whakaoti rapanga te ākonga, ka whakamārama otinga, e whai wāhi mai ana:	He taura ēnei o ngā āhuetanga me mātua mōhio te ākonga e tutuki ai tana whakaoti rapanga:	
<ul style="list-style-type: none"> <li>te whakaatu pānga hei kupu, hei tūtohi, hei kauwhata, hei whārite hoki</li> <li>te whakaoti whārite taurangi<sup>11</sup> mā mā, pērā i te <math>3t + 5 = 47</math>.</li> </ul>	<ul style="list-style-type: none"> <li>te whakamahinga o te āhuetanga kōaro<sup>9</sup>, te āhuetanga herekore<sup>10</sup>, me te āhuetanga tohatoha<sup>12</sup> hei whakaoti whārite</li> <li>te tikanga o te tuaka pou, te tuaka pae, me te takirua raupapa hei whakaatu i te pānga o ētahi taurangi<sup>13</sup> e rua ki te kauwhata</li> <li>te tikanga o te rārangi o tētahi kauwhata hei whakaatu i te pānga o ētahi taurangi e rua.</li> </ul>	<p><sup>9</sup>commutative property</p> <p><sup>10</sup>associative property</p> <p><sup>11</sup>algebraic equation</p> <p><sup>12</sup>distributive property</p> <p><sup>13</sup>variable</p>

## Te Reo Matatini o te Pāngarau

Hei taura kupu		
• pānga	• ture	• taurangi
Hei taura whakaahuahanga		
• tūtohi	• kauwhata rārangi	• whārite

## He Taura Rapanga

### Te Taura me te Pānga 4e

### Rapanga 6

Titiro ki te taura porotiti nei. He taura raupapa. E whakaaturia ana te hanga tuatahi me te hanga tuarua o te taura.

- Tuhia te hanga tuatoru o te taura.
- Whakamāramatia mai te tipu o te taura.
- He tūtohi tēnei e whakaatu ana i te maha o ngā porotiti kākāriki me te maha o ngā porotiti kōwhai o ia hanga o te taura. Māu e whakaoti te tūtohi.

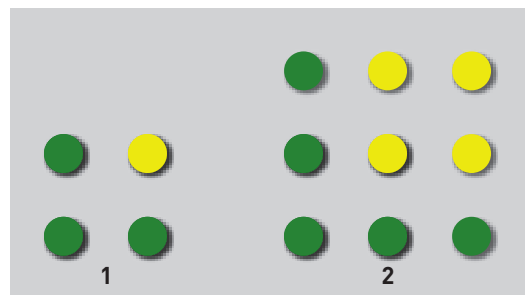

Te hanga	Ngā porotiti kākāriki	Ngā porotiti kōwhai
1	3	1
2	5	4
3	7	9
4		
5		
100		



Kia tika te tuhi i te hanga tuatoru me te whakamārama i te tipu o te tauira. Hei tauira:

Ka tāpirihia tētahi porotiti kākāriki ki te tapa mauī me te tapa raro o te tapawhā rite, ā, ka tāpirihia he porotiti kōwhai hei whakaoti i te tapawhā rite.

Ka whakamahia he rautaki taurangi hei whiriwhiri i ngā porotiti mō te hanga 100. Arā, ka āta kitea te pānga o te hanga me te maha o ngā porotiti kākāriki me te maha o ngā porotiti kōwhai:

Te hanga	Ngā porotiti kākāriki	Ngā porotiti kōwhai
1	$1 \times 2 + 1 = 3$	$1^2 = 1$
2	$2 \times 2 + 1 = 5$	$2^2 = 4$
3	$3 \times 2 + 1 = 7$	$3^2 = 9$
4	$4 \times 2 + 1 = 9$	$4^2 = 16$
5	$5 \times 2 + 1 = 11$	$5^2 = 25$
100	$100 \times 2 + 1 = 201$	$100^2 = 10\,000$

## Te Tauira me te Pānga 4e

### Rapanga 7

E \$250 i roto i te pūtea pēke a Hinemoana i te tīmatanga, ā, ka tangohia te \$30 i ia wiki hei utu i tētahi hokonga harangotengote āna.



1. Tuhia he tūtohi hei whakaatu i te tapeke o te pūtea pēke a Hinemoana i te paunga o ngā wiki 1 ki te 5.
2. Tuhia he whārite hei tātai i te tapeke o te pūtea pēke a Hinemoana.
3. E hia te tapeke o te pūtea i te paunga o te 10 wiki?
4. E hia wiki kia heke te tapeke o te pūtea ki raro i te kore?
5. E hia wiki kia heke te tapeke o te pūtea ki te \$350 tōraro [−\$350]?

Kia tika ngā otinga, hei whakaatu i te mōhio ki te tuhi whārite taurangi e hāngai ana ki tētahi pūhaha whitake māmā, me te whakamahi anō i te whārite hei tātai i ngā taurangi.

## Te Ine me te Hanga

Ngā Whāinga		
Ka whakaoti rapanga te ākongā, ka whakamārama otinga, e whai wāhi mai ana:	He tauira ēnei o ngā āhuatanga me mātua mōhio te ākongā e tutuki ai tana whakaoti rapanga:	
<ul style="list-style-type: none"> <li>ngā momo wātaka whānui</li> <li>te whiriwhiri i te rahi o tētahi koki.</li> </ul>	<ul style="list-style-type: none"> <li>te tātai i te takanga o te wā</li> <li>te whakaatu wā-24</li> <li>te tikanga o te koki whakahāngai<sup>14</sup>, te koki whakarārangi<sup>15</sup>, te koki whakahuripū<sup>16</sup>, te koki tāhapa<sup>17</sup>, me te koki hāpūpū<sup>18</sup>.</li> </ul>	<p><sup>14</sup>complimentary angle</p> <p><sup>15</sup>supplementary angle</p> <p><sup>16</sup>conjugate angle</p> <p><sup>17</sup>acute angle</p> <p><sup>18</sup>obtuse angle</p>

## Te Reo Matatini o te Pāngarau

Hei tauira kupu		
<ul style="list-style-type: none"> <li>wātaka</li> <li>koki whakarārangi</li> <li>koki hāpūpū</li> </ul>	<ul style="list-style-type: none"> <li>wā-24</li> <li>koki whakahuripū</li> <li>koki roto</li> </ul>	<ul style="list-style-type: none"> <li>koki whakahāngai</li> <li>koki tāhapa</li> </ul>

## He Tauira Rapanga

### Te Ine me te Hanga 4e

### Rapanga 8

Kei mua te tāima o Aotearoa i ērā atu whenua o te ao:

- 12 hāora kei mua i Ingarangi
- e 2 hāora kei mua i Piripane (Brisbane)
- e  $4\frac{1}{2}$  hāora kei mua i Malaysia
- 17 hāora kei mua i Washington.

- He aha te tāima i Piripane (Brisbane) mēnā ko te 1425 hāora te tāima i Aotearoa?
- He aha te tāima i Aotearoa mēnā ko te 0930 hāora te tāima i Ingarangi?
- Kei Aotearoa a Hinewai. Kei te waea atu a Hinewai ki tana kuia kei Ingarangi e noho ana. E hiahia ana ia kia tangi te waea a tōna kuia i te 8.00 karaka i te pō. He aha te tāima me waea atu a Hinewai i Aotearoa?
- E hoki mai ana a Hororangi mai i Washington ki Aotearoa. Ka wehe mai ia i te 0900 hāora i te 5 o Mahuru. 18 hāora te roa o te rerenga. He aha te rā me te tāima i Washington i tana taunga mai ki Aotearoa? He aha te rā me te tāima i Aotearoa i tana taunga mai?

Kia tika te whiriwhiri i ngā taima, me te whakamārama rautaki:

- 1225 hāora
- 2130 hāora
- 8:00 i te ata
- 0300 hāora i te ata o te 6 o Mahuru i Washington, ā, 2000 hāora i te pō o te 6 o Mahuru i Aotearoa.

Hei tauira whiriwhiringa:

- Ka tāpirihia te 18 hāora ki te 0900 hei whiriwhiri i te tāima i Washington:

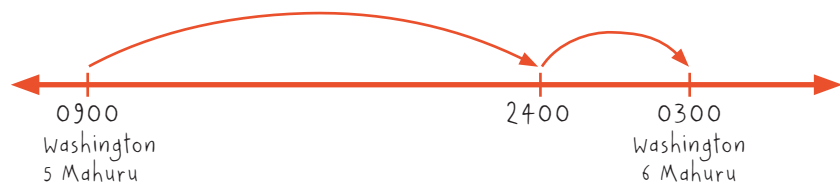

- 17 hāora te tōmua o Aotearoa i Washington, nō reira ko te 2000 hāora tērā i te 6 o Mahuru:



## Te Ine me te Hanga 4e

### Rapanga 9

He whakarahinga tēnei o tētahi wāhanga o tētahi taurira tāniko.

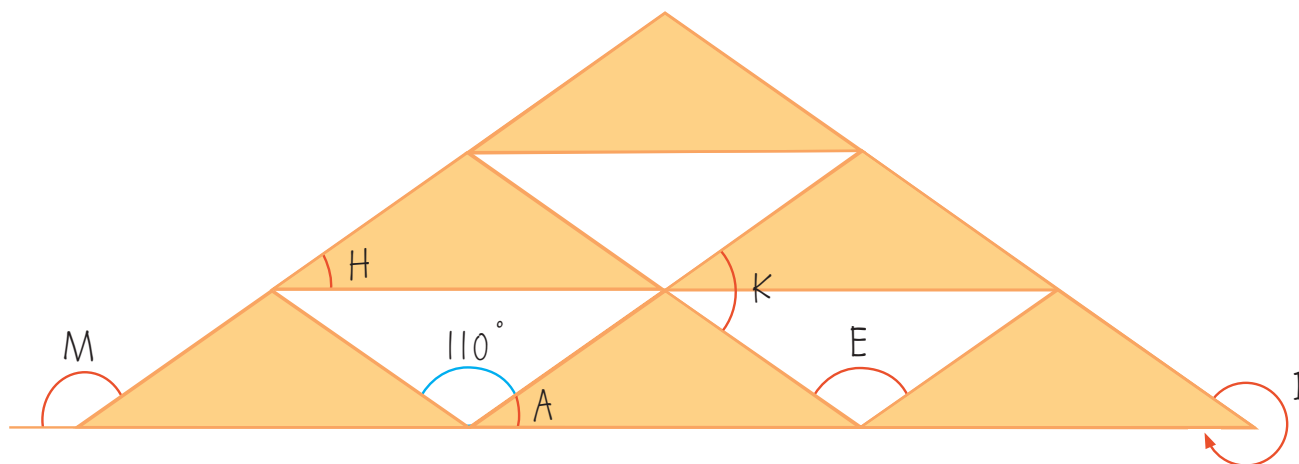

Whiriwhiria te rahi o ngā koki e tohua ana, ka whakamārama mai ai.

Kia tika te whiriwhiri me te whakamārama i ngā koki. Hei taurira:

- |                      |  |
|----------------------|--|
| Koki A = $35^\circ$  | E rua o ēnei koki me te koki $110^\circ$ , ka rite ki te $180^\circ$ (koki whakarārangi).                                |
| Koki E = $110^\circ$ | He nekehanga o te tapatoru e tohua mai ana te koki $110^\circ$ . Ka pūmau tonu te koki i roto i te nekehanga.            |
| Koki H = $35^\circ$  | He nekehanga o te tapatoru. E $35^\circ$ ngā koki iti o ngā tapatoru katoa. Ka pūmau tonu te koki i roto i te nekehanga. |
| Koki I = $325^\circ$ | Ko te $360^\circ$ te tapeke o tēnei koki me te koki $35^\circ$ e noho mai ana ki roto i te tapatoru (koki huripū).       |
| Koki K = $70^\circ$  | E rua ngā koki iti o ngā tapatoru ( $35^\circ + 35^\circ$ ).   |
| Koki M = $145^\circ$ | Ko te $180^\circ$ te tapeke o tēnei koki me te koki $35^\circ$ e noho mai ana ki roto i te tapatoru (koki whakarārangi). |

## Te Wāhi, te Ahunga, me te Panoni

Ngā Whāinga		
Ka whakaoti rapanga te ākonga, ka whakamārama otinga, e whai wāhi mai ana:	He tauira ēnei o ngā āhuratanga me mātua mōhio te ākonga e tutuki ai tana whakaoti rapanga:	
<ul style="list-style-type: none"> <li>te ōwehenga hei tātai taurahi<sup>19</sup>, hei tātai hoki i te rahi o tētahi mātātuhi<sup>20</sup> whakarahi</li> <li>tētahi raupapatanga panoni<sup>21</sup>.</li> </ul>	<ul style="list-style-type: none"> <li>te hua o te whakarahi āhua (pērā i te pānga ki te roa o ngā tapa, te horahanga, me te rōrahi).</li> </ul>	<sup>19</sup> scale factor <sup>20</sup> image <sup>21</sup> combined transformation

## Te Reo Matatini o te Pāngarau

Hei tauira kupu		
<ul style="list-style-type: none"> <li>raupapatanga panoni</li> <li>mātāoroko</li> </ul>	<ul style="list-style-type: none"> <li>taurahi</li> <li>mātātuhi</li> </ul>	<ul style="list-style-type: none"> <li>pū whakarahi</li> <li>ōwehenga</li> </ul>

## He Tauira Rapanga

Te Wāhi, te Ahunga, me te Panoni 4e

### Rapanga 10

He whakarahinga te tapatoru E o te tapatoru A.

A

E

- He aha te taurahi?
- E hia te roa o te tapa poto o te tapatoru whakarahi?
- E hia te roa o te tāroa o te tapatoru whakarahi?

Kia mōhio te ākonga ki te whiriwhiri i te taurahi, arā, te whiriwhiri i te tau whakarea i te 6.3 kia hua mai ai te 25.2. (Ko te 4 tērā.)

Kia tika te whakamahi i te taurahi hei whiriwhiri i ngā tapa (tapa poto =  $4.1 \times 4 = 16.4$  cm; tāroa =  $7.5 \times 4 = 30$  cm).

Te Wāhi, te Ahunga, me te Panoni 4e

### Rapanga 11

He whakarahinga te tapawhā hāngai E o te tapawhā hāngai A. Ko te 3 te taurahi. Ko te  $3.8 \text{ cm}^2$  te horahanga o te A. He aha te horahanga o te tapawhā hāngai E?

A

E

Kia mōhio te ākonga ki te pānga o te taurahi me te horahanga.

Kia tika tana tātai i te horahanga o te tapawhā hāngai E:

- Ka pūruatia te taurahi  $3^2 = 9$  (koia te whakareatanga ake o te horahanga).
- Ka whakareatia te horahanga o te A ki te pūrua o te taurahi, arā,  $3.8 \times 9 = 34.2$ .

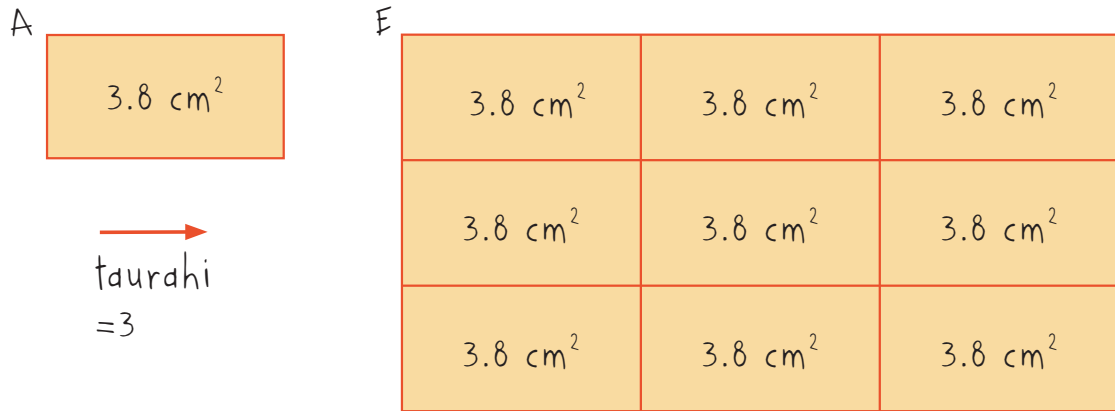

Te Wāhi, te Ahunga, me te Panoni 4e

## Rapanga 12

1. Tohua ngā pūwāhi nei ki tētahi papa tukutuku: A = (2,3) E = (4,3) H = (3,6)
2. Honoa ēnei pūwāhi hei tapatoru.
3. Hurihia te tapatoru nei, kia 90° whakatekaraka. Ko te (3,2) hei pū o te hurihanga.
4. Whakaatanga ngā tapatoru e rua nei. Ko te rārangi e hono ana i te (2,7) me te (8,1) hei rārangi whakaata.
5. He aha te āhua kua puta mai i waenganui i ngā tapatoru?

Kia tika te whakaatu i te raupapatanga panoni nei ki te pepa tukutuku. Arā:

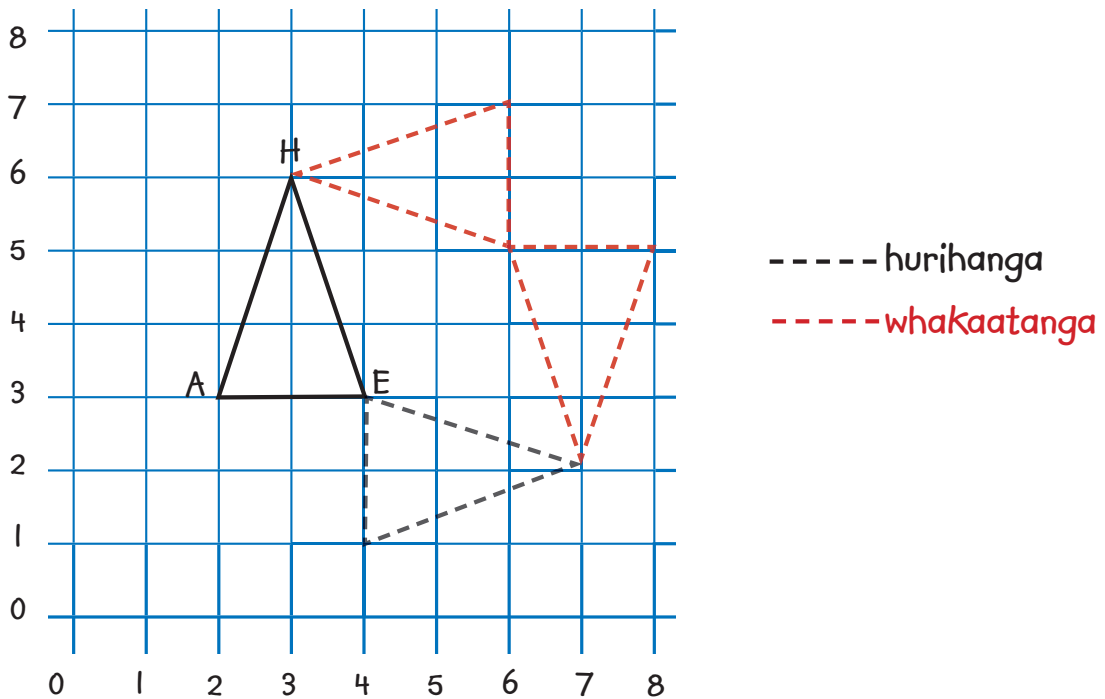

Ka whakaaturia te mōhio ki te:

- whakaatu pūwāhi ki te papa tukutuku
- whakaoti raupapatanga panoni i te papa tukutuku.

## Te Tauanga

Ngā Whāinga		
Ka whakaoti rapanga te ākonga, ka whakamārama otinga, e whai wāhi mai ana:	He tauira ēnei o ngā āhuratanga me mātua mōhio te ākonga e tutuki ai tana whakaoti rapanga:	
<ul style="list-style-type: none"> <li>te <b>tātari</b><sup>22</sup> i ngā whakakitenga o tētahi tūhuratanga tauanga</li> <li>te <b>arohaehae</b><sup>24</sup> i te tōtika o te <b>tukanga kohikohi raraunga</b><sup>25</sup>, me te whakaari i ngā raraunga o tētahi <b>tīpako</b><sup>27</sup>, hei whakaatu i te āhua o tētahi <b>taupori</b><sup>28</sup>.</li> </ul>	<ul style="list-style-type: none"> <li>te whakaatu raraunga ki te <b>kauwhata pouhere</b><sup>23</sup></li> <li>ngā <b>tikanga matatika</b><sup>26</sup> e hāngai ana (pērā i te whakamōhio atu ki te kaiwhakautu pātai i te whakamahinga o ngā raraunga ka puta i te tūhuratanga tauanga).</li> </ul>	<p><sup>22</sup><i>analyse</i></p> <p><sup>23</sup><i>histogram</i></p> <p><sup>24</sup><i>critique</i></p> <p><sup>25</sup><i>data collection process</i></p> <p><sup>26</sup><i>ethical conventions</i></p> <p><sup>27</sup><i>sample</i></p> <p><sup>28</sup><i>population</i></p>

## Te Reo Matatini o te Pāngarau

Hei tauira kupu		
• pānga	• ture	• taurangi
Hei tauira whakaahuahanga		
• kauwhata pouhere		

## He Tauira Rapanga

### Te Tauanga 4e

### Rapanga 13

Kua tae mai tētahi tangata hou ki te whakahaere i te toa kai o tētahi kura nui (e 600 ngā ākonga). E whakaaro ana ia kia whakahaerehia tētahi uiuitanga kia mōhio ai ngā whakaaro o te hapori o te kura mō ngā momo kai hei hoko māna i te toa. Pēhea nei ō whakaaro mō ēnei tīpako hei uiui māna?

- Ka uiui i tētahi ākonga mai i ia akomanga o te kura.
- Ka uiui i ngā mātua me ngā pouako.
- Ka tukuna he tono kia huihui mai te hapori o te kura, ā, ka uiui i te hunga ka tae atu ki te hui.
- Ka uiui i ngā tūākana o te kura.
- Ka tīpako matapōkere i ngā ākonga tekau o roto i ngā ākonga katoa o te kura.
- Ka tīpako matapōkere i ngā ākonga kotahi rau o roto i ngā ākonga katoa o te kura.

**Kia mārama ki ngā painga me ngā whakararu o ia tīpako. Hei tauira:**

He tokoiti pea te tīpako tuatahi kia tino mōhio ai ngā whakaaro o te hapori katoa o te kura. Kāore i whai wāhi mai ngā pouako me ngā mātua. Engari, nā te tokoiti o te tīpako he māmā te whakahaere i te uiuitanga me te kohikohi i ngā raraunga.

## Te Tauanga 4e

### Rapanga 14

**Rauemi:** He rorohiko me tētahi hōtaka ripanga.

	A	B	C	D	E	F	G
1		Kaiwhakawā 1	Kaiwhakawā 2	Kaiwhakawā 3	Kaiwhakawā 4	Kaiwhakawā 5	Kaiwhakawā 6
2	Whakaeke	76	72	75	80	62	95
3	Poi	93	72	67	89	65	90
4	Waiata ā-ringa	63	67	67	71	65	92
5	Waiata tira	87	73	70	76	67	90
6	Mōteatea	82	70	74	75	64	91
7	Haka	64	68	65	69	68	88
8	Whakawātea	94	95	87	83	65	92

Hoatu te tūtohi i runga nei ki ngā ākongā, me te tono kia whakaurua ki te hōtaka ripanga. Koinei ngā māka a ētahi kaiwhakawā e ono i tukuna ki tētahi kapa haka i tētahi whakataetae.

- He aha te māka kotahi hei whakaatu i ngā whakaaro o te Kaiwhakawā 1 mō tēnei kapa haka? Me pēhea te tātai ā-ringa i te māka?
- Tohua te rorohiko kia tātaihia te toharite a ia kaiwhakawā.
- Me pēhea te tātai i te māka kotahi e tika ana mō tēnei kapa haka?
- Whakaaturia ngā māka ki tētahi kauwhata pou kia kitea ai ngā māka mō ia momo whakatū waewae a tēnei kapa.
- Whakaaturia ngā māka ki tētahi kauwhata pou kia kitea ai ngā māka a ia kaiwhakawā.
- Tukuna he pātai, ka tono rānei mā ngā ākongā e whakaputa kōrero mō ēnei raraunga. Hei tauria:
  - ◇ Ko wai ngā kaiwhakawā he āhua ōrite ngā māka mō ia momo whakatū waewae, kāore e tino piki, e tino heke rānei ngā māka, arā, kāore e manei?
  - ◇ Ko wai ngā kaiwhakawā ka āhua manei ā rātou māka, arā, ka piki, ka heke?
  - ◇ He aha ngā kōrero mō te kaiwhakawā 6?
  - ◇ Hāunga te kaiwhakawā 6, ko ēhea ngā momo whakatū waewae he āhua ōrite ngā māka?
  - ◇ He aha ngā momo whakatū waewae e tino eke ana tēnei kapa haka i te taumata, he aha hoki ngā momo whakatū waewae kāore i te pērā rawa te pai?

**Kia mōhio ki te whakamahi hōtaka ripanga rorohiko ki te tātai toharite, ki te whakaputa kauwhata hoki.**

**Kia mōhio ki te tikanga o te toharite me te tātai i te toharite.**

**Kia tika te tūhura i ngā raraunga me ngā kauwhata hei whakautu i ngā pātai.**

## Te Tūponotanga

Ngā Whāinga		
Ka whakaoti rapanga te ākonga, ka whakamārama otinga, e whai wāhi mai ana:	He tauira ēnei o ngā āhuatanga me mātua mōhio te ākonga e tutuki ai tana whakaoti rapanga:	
<ul style="list-style-type: none"> <li>te whakatairite i te tuari<sup>29</sup> o ngā putanga matapae<sup>30</sup> me ngā putanga whakamātau<sup>31</sup>.</li> </ul>	<ul style="list-style-type: none"> <li>ngā take e taurangi<sup>32</sup> ai ngā putanga o tētahi whakamātau tūponotanga.</li> </ul>	<sup>29</sup> distribution <sup>30</sup> theoretical outcome <sup>31</sup> experimental outcome <sup>32</sup> variable

## Te Reo Matatini o te Pāngarau

Hei tauira kupu		
<ul style="list-style-type: none"> <li>tūponotanga</li> <li>matapae</li> </ul>	<ul style="list-style-type: none"> <li>putanga</li> <li>whakamātau</li> </ul>	<ul style="list-style-type: none"> <li>pāpono</li> <li>tuari</li> </ul>

## He Tauira Rapanga

### Te Tūponotanga 4e

### Rapanga 15

**Rauemi:** He pūrere takahurihuri.

E rua ngā takahurihanga o te pūrere nei, ka tāpirihia ngā putanga o ngā takahurihanga e rua. Hei tauira, mēnā he 2 te takahurihanga tuatahi, ā, he 3 te takahurihanga tuarua, ko te 5 te tapeke.

- Tuhia he hoahoa rākau hei whakaatu i ngā tapeke katoa e taea ana.
- He aha te tūponotanga ko te 2 te tapeke o ngā takahurihanga e rua?
- He aha te tūponotanga ko te 3 te tapeke?
- He aha te tūponotanga ko te 1 te tapeke?
- He aha te tūponotanga he nui ake i te 4 te tapeke?
- Tāia he kauwhata pou hei whakaatu i ngā tapeke katoa e taea ana, me te tūponotanga o tēnā, o tēnā:

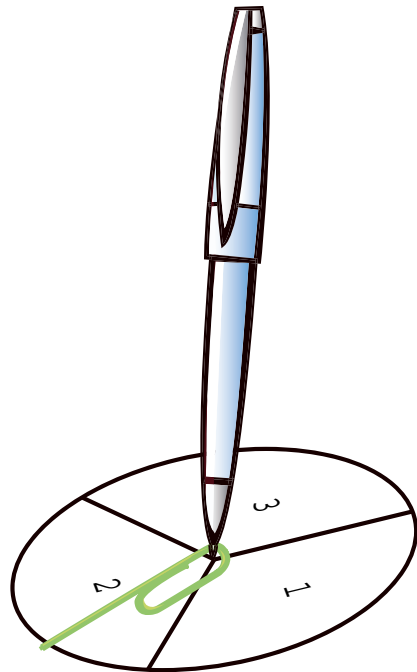
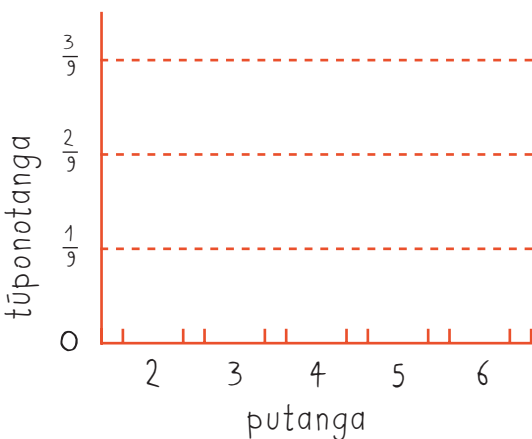

- Mēnā 18 ngā takahurihanga e rua o te pūrere, he aha tō matapae mō te maha o ngā putanga o tēnā tapeke, o tēnā?
- Whakamātauria tāu i matapae ai, ka whakaatu ai i ngā putanga matapae me ngā putanga whakamātau ki tētahi kauwhata pou hiato.
- He aha i rerekē ai ngā putanga matapae me ngā putanga whakamātau?

**Kia tika te whakautu i ngā pātai, te whakaatu i ngā putanga katoa e taea ana ki te hoahoa rākau, te tātai i ngā tūponotanga o ngā putanga, te whakahaere i te whakamātau, me te tuhi i te kauwhata pou hiato.**



## Te Tau: Te Mātauranga Tau me ngā Rautaki Tau

(TPT) Kaupae 8

Ngā Whāinga		
Ka whakaoti rapanga te ākonga, ka whakamārama otinga, e whai wāhi mai ana:	He tauira ēnei o ngā āhuatanga me mātua mōhio te ākonga e tutuki ai tana whakaoti rapanga:	
<ul style="list-style-type: none"> <li>ngā tau tōpū<sup>1</sup> me ngā tau hautanga</li> <li>te kōwhiri i te rautaki paheko tau<sup>3</sup> e tino hāngai ana ki te horopaki.</li> </ul>	<ul style="list-style-type: none"> <li>ngā tikanga me te whakamahinga o te tānga ngahuru<sup>2</sup> hei tohu i ngā tau tino nui, tino iti hoki</li> <li>ngā momo hātepe<sup>4</sup> whakaoti paheko hautau.</li> </ul>	<p><sup>1</sup>integer, <sup>2</sup>standard form <sup>3</sup>number operation <sup>4</sup>algorithm</p>

## Te Reo Matatini o te Pāngarau

Hei tauira kupu		
<ul style="list-style-type: none"> <li>tau tōpū</li> <li>pāpātanga</li> <li>whakatau tata</li> </ul>	<ul style="list-style-type: none"> <li>tānga ngahuru</li> <li>hautanga ōrite</li> <li>tātaiai</li> </ul>	<ul style="list-style-type: none"> <li>hātepe poutū</li> <li>ōwehenga</li> <li>whakaawhiwhi</li> </ul>

## He Tauira Rapanga

Te Tau 5a

### Rapanga 1

E 5 ngā rēme pango a Kaipāmu Hinewai, kei te takiwā tērā o te 21% o ana rēme katoa.

- Me whakatau tata te maha o ana rēme katoa, ka whakamārama ai.
- Tātaihia te maha o ana rēme katoa, ka whakamārama ai i ō mahi.

- Kia tika te whakatau tata me tētahi whakamārama pēnei:

E pātata ana te 21% ki te 20%. Ko te  $\frac{1}{5}$  tērā. Mēnā ko te 5 te  $\frac{1}{5}$  o ana rēme, ko te 25 (5 x 5) te maha o ana rēme katoa. Ko te 25 te whakatau tata o ngā rēme katoa, engari, he iti iho i te 25, nā te mea he iti iho te 20% i te 21%.

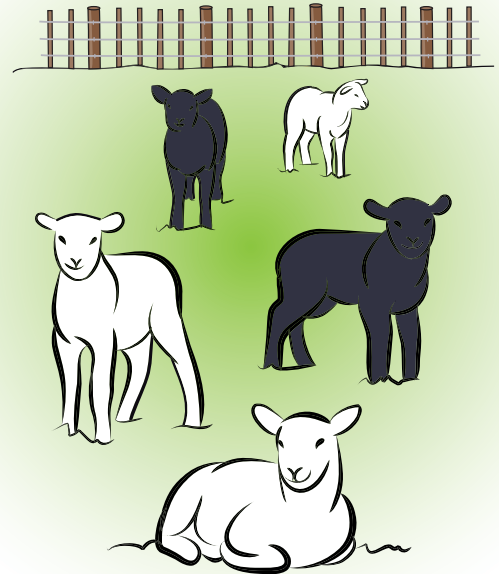
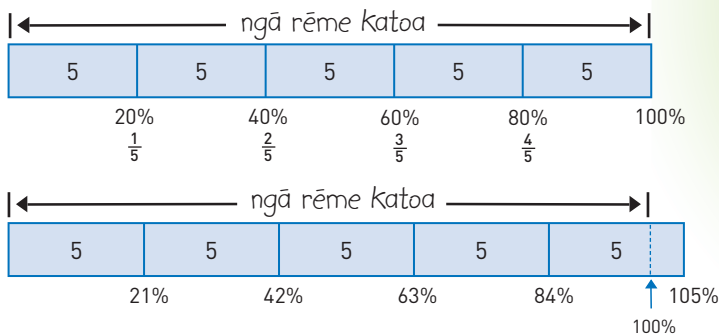

- Kia tika hoki te tātai i te maha o ngā rēme katoa. E hāngai ana te 5 ki te 21%. Nō reira wehea te 5 ki te 21 hei tātai i te maha o ngā rēme mō ia ōrau. Ko te 0.238 tērā (mā te tātaiai). Ināianei, me whakarea te 0.238 ki te 100 hei tātai i te 100% o ana rēme. Ko te 23.8. Kāore e taea te 0.8 rēme, nō reira me whakaawhiwhi ki runga, ki te 24. E 24 katoa ngā rēme a Kaipāmu Hinewai.

$\begin{array}{r} \text{rēme} \\ \hline 5 \\ \div 21 \rightarrow 5 \div 21 \\ \times 100 \rightarrow 5 \div 21 \times 100 \end{array}$	$\begin{array}{r} \text{ōrau} \\ \hline 21 \\ \div 21 \rightarrow 1 \\ \times 100 \rightarrow 100 \end{array}$
--	--

## Te Tau 5a

### Rapanga 2

E 56 km ka oti i tētahi motukā i te 35 meneti.

- Mēnā ka pūmau tonu te tere o tēnei motukā, whakataua tatahia ngā meneti e oti ai te 24 km.
- Mēnā ka pūmau tonu te tere o tēnei motukā, tātaihia ngā meneti e oti ai te 24 km.



- Kia tika te whakataua tata, me tētahi whakamārama pēnei:

Mēnā ka hauruatia te 56 km, ko te 28 km. Ka hauruatia te 35 meneti, ka 17.5. He iti iho i tēnā, nā te mea he iti iho te 24 km i te 28 km. Nō reira ka oti te 24 km i te 15 meneti.

tawhiti (km)	wā (meneti)
56 km	35 meneti
28 km	17.5 meneti
24 km	15 meneti

- Kia tika hoki te tātaianga me tētahi whakamārama pēnei:

tawhiti (km)	wā (meneti)						
$\div 56$ <table style="display: inline-table; vertical-align: middle;"> <tr><td>56</td></tr> <tr><td>1</td></tr> <tr><td>24</td></tr> </table>	56	1	24	$\div 35$ <table style="display: inline-table; vertical-align: middle;"> <tr><td>35</td></tr> <tr><td><math>\frac{35}{56}</math></td></tr> <tr><td>15</td></tr> </table>	35	$\frac{35}{56}$	15
56							
1							
24							
35							
$\frac{35}{56}$							
15							

$(\frac{35}{56} \times 24 = 15 - \text{mā te tātaianga})$

Wehea te 56 km ki te 56, ko te 1 km tērā. Me wehe anō te 35 meneti ki te 56, ko te  $\frac{35}{56}$  meneti e oti ai te manomita kotahi. Ināianei me whakarea te tawhiti me te wā ki te 24, ka 24 km i roto i te 15 meneti ( $\frac{35}{56} \times 24 = 15$ ).

## Te Tau 5a

### Rapanga 3

E rua me te haurua rita ( $2\frac{1}{2}$  L) te rōrahi o te wai ārani, ka wehea ki ētahi kapu kia  $\frac{3}{10}$  rita te kītanga o tēnā me tēnā.

- Whakataua tatahia te maha o ngā kapu ka taea te whakakī, ka whakamārama ai.
- Tātaihia te maha o ngā kapu ka taea te whakakī, ka whakamārama ai i ō mahi.

Kia tika te whakataua tata me tētahi whakamārama pēnei:

Mēnā e  $\frac{3}{10}$  rita te kītanga o ia ipu, e 3 ipu ka kī i te rita kotahi ( $3 \times \frac{3}{10} = \frac{9}{10}$ ), ā, ka toe mai he paku wai ārani ( $\frac{1}{10}$  rita). Nō reira, e 6 ipu ka kī i ngā rita e rua, e  $7\frac{1}{2}$  ka kī i te  $2\frac{1}{2}$  rita, me ētahi wai ārani e toe ana. Nō reira, kei te takiwā pea o te 8 ngā ipu.



- Kia tika hoki te tātaianga me tētahi whakamārama pēnei:

Ka hurihia te  $2\frac{1}{2}$  hei hautau, ko te  $\frac{5}{2}$  tērā. Ka whakaurua tērā ki te whārite hei whakaata i te rapanga:

$$\frac{5}{2} \div \frac{3}{10} = \square$$

Ko te ture mō te whakawehe ki tētahi hautau, me huri te whakawehenga hei whakareatanga, me te huripoki anō i te hautau whakawehe. Arā:

$$\begin{aligned} \frac{5}{2} \div \frac{3}{10} &= \frac{5}{2} \times \frac{10}{3} \\ &= \frac{50}{6} \\ &= 8\frac{2}{6} \\ &= 8\frac{1}{3} \end{aligned}$$

E 8 me te hautoru ipu.

# WHANAKETANGA 5a

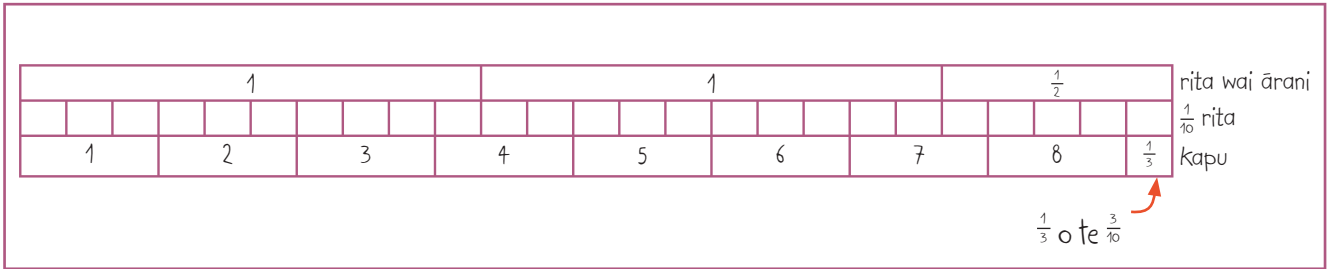

## Te Tau 5a

### Rapanga 4

E 300 000 manomita i te hākona te tere o te whātoro o te aho. Tātaihia te tawhiti o te whātoro o te aho i te tau kotahi. Ka kīia tēnei ko te tau aho, ā, ka whakamahia hei ine i ngā tawhiti nui tonu o tuarangi. Tuhia te tau aho hei tānga ngahuru.

**Kia tika te tātai i te tau aho, te tuhi hei tānga ngahuru, me tētahi whakamārama pēnei:**

$$\begin{aligned}
 \text{te tere o te aho} &= 300\,000 \text{ manomita i te hākona} \\
 &= 300\,000 \times 60 \text{ manomita i te meneti} \\
 &= 300\,000 \times 60 \times 60 \text{ manomita i te hāora} \\
 &= 300\,000 \times 60 \times 60 \times 24 \text{ manomita i te rā} \\
 &= 300\,000 \times 60 \times 60 \times 24 \times 365 \text{ manomita i te tau} \\
 &= 9\,460\,000\,000\,000 \text{ manomita i te tau}
 \end{aligned}$$

$$\begin{aligned}
 1 \text{ te tau aho} &= 9\,460\,000\,000\,000 \text{ km} \\
 &= 9.46 \times 10^{12} \text{ km}
 \end{aligned}$$

## Te Tau 5a

### Rapanga 5

Nā Waiora te kotahi hauwhā ( $\frac{1}{4}$ ) o ngā piro o tana tīma poitarawhiti. Kotahi hautoru ( $\frac{1}{3}$ ) nā Kahurangi. Nā Mereana te toenga o ngā piro. Mēnā e 72 katoa ngā piro a tēnei tīma, e hia ngā piro a Mereana?

**Kia tika te otinga (30), mā tētahi rautaki pēnei:**

- Ka whiriwhiria te hautanga o ngā piro a Mereana i te tuatahi:

$$\begin{aligned}
 \frac{1}{4} + \frac{1}{3} & \text{ (tāpirihia te hautanga o ngā piro a Waiora rāua ko Kahurangi)} \\
 &= \frac{3}{12} + \frac{4}{12} = \frac{7}{12}
 \end{aligned}$$

Nō reira ko te  $\frac{5}{12}$  te hautanga e toe ana – koirā te hautanga piro a Mereana.

**Ka whiriwhiria te  $\frac{5}{12}$  o te 72:**

$$\begin{aligned}
 \frac{1}{12} \text{ o te } 72 & \longleftrightarrow 72 \div 12 = 6 \\
 \frac{5}{12} \text{ o te } 72 & \longleftrightarrow 6 \times 5 = 30
 \end{aligned}$$

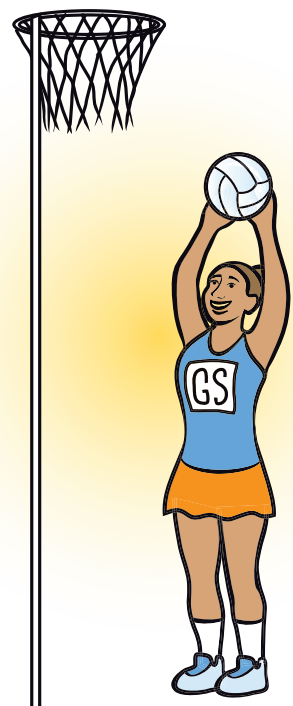

# WHANAKETANGA 5a

## Te Taura me te Pānga

Ngā Whāinga		
Ka whakaoti rapanga te ākonga, ka whakamārama otinga, e whai wāhi mai ana:	He tauira ēnei o ngā āhuatanga me mātua mōhio te ākonga e tutuki ai tana whakaoti rapanga:	
<ul style="list-style-type: none"> <li>te whārite me te kauwhata rārangi hei whakaatu pānga.</li> </ul>	<ul style="list-style-type: none"> <li>te tikanga o ngā haukotinga tuaka<sup>5</sup> me te rōnaki<sup>6</sup> o tētahi kauwhata rārangi, me te puta o ēnei i rō whārite.</li> </ul>	<sup>5</sup> axis intercept <sup>6</sup> slope

## Te Reo Matatini o te Pāngarau

Hei tauira kupu		
<ul style="list-style-type: none"> <li>rōnaki</li> <li>tuaka pae</li> <li>whārite</li> </ul>	<ul style="list-style-type: none"> <li>haukotinga-y</li> <li>tuaka pou</li> <li>taurangi</li> </ul>	<ul style="list-style-type: none"> <li>haukotinga-x</li> <li>ture</li> <li>kauwhata rārangi</li> </ul>

## He Taura Rapanga

### Te Taura me te Pānga 5a

### Rapanga 6

E rua ngā kamupene tēkehi (waka tonu). Koia nei ngā utu:

- Tēkehi A: \$5.00 mō te tonu me te \$3.00 mō ia manomita.
- Tēkehi E: \$3.00 mō te tonu me te \$4.00 mō ia manomita.

- Tuhia he ture ā-kupu hei tātai i ngā utu mō ngā tēkehi e rua nei.
- Tuhia he whārite hei tātai i ngā utu mō ngā tēkehi nei.
- Whakaaturia ngā whārite e rua ki tētahi kauwhata rārangi.
- He aha te rōnaki o ia kauwhata?
- Ko tēhea te tēkehi he māmā ake te utu? Whakamāramatia māi.

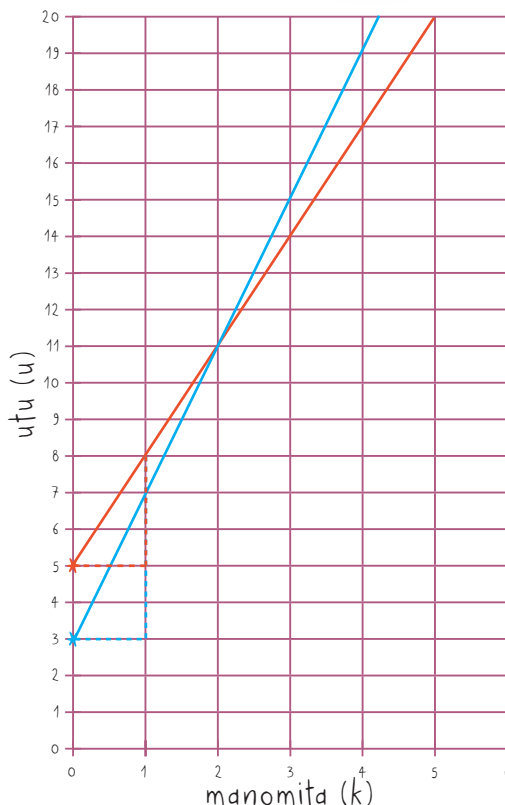
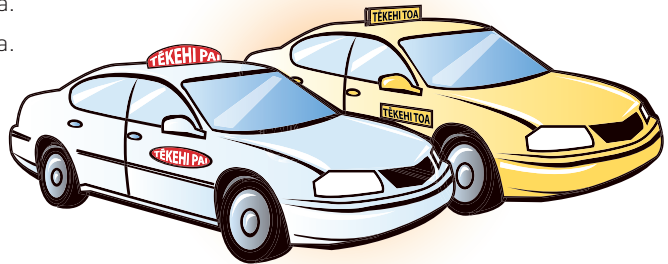

Tēkehi A

Tēkehi E

Kia tika te tuhi i ngā ture e rua nei:

Tēkehi A: Whakareatia te maha o ngā manomita ki te 3, ka tāpiri i te 5 hei tātai i te utu.

Tēkehi E: Whakareatia te maha o ngā manomita ki te 4, ka tāpiri i te 3 hei tātai i te utu.

Kia tika te tuhi i ngā whārite e rua nei:

Tēkehi A:  $u = 3k + 5$

Tēkehi E:  $u = 4k + 3$

Kia tika te whakaatu i ngā whārite ki te kauwhata, mā te tautohu i te haukotinga-y me te whiriwhiri i te rōnaki o ia whārite:

Tēkehi A: Haukotinga-y = 5, Rōnaki = 3

Tēkehi E: Haukotinga-y = 3, Rōnaki = 4

He ōrite te utu o ngā tēkehi e rua nei mēnā e 2 km te tawhiti o te haere. Ki raro i te 2 km, ko te Tēkehi E te mea he māmā te utu. Ki runga ake i te 2 km, ko te Tēkehi A te mea he māmā te utu.

## Te Ine me te Hanga

Ngā Whāinga		
Ka whakaoti rapanga te ākonga, ka whakamārama otinga, e whai wāhi mai ana:	He tauira ēnei o ngā āhuatanga me mātua mōhio te ākonga e tutuki ai tana whakaoti rapanga:	
<ul style="list-style-type: none"> <li>ngā ture<sup>7</sup> hei tātai tapa, paenga, horahanga, koki, horahanga mata, rōrahi hoki o ngā āhua whānui</li> <li>ngā tikanga koki o te rārangi pūtahi<sup>12</sup>, te rārangi whakarara, me ngā taparau.</li> </ul>	<ul style="list-style-type: none"> <li>te whakamahi i te ture a Pythagoras</li> <li>te tikanga o te koki tauaro<sup>8</sup>, te koki tauaro<sup>9</sup>, te koki taurite<sup>10</sup>, me te koki tauwhiti<sup>11</sup></li> </ul>	<p><sup>7</sup>formulae</p> <p><sup>8</sup>interior angle</p> <p><sup>9</sup>opposite angle</p> <p><sup>10</sup>corresponding angle</p> <p><sup>11</sup>alternate angle</p> <p><sup>12</sup>intersecting lines</p>

## Te Reo Matatini o te Pāngarau

Hei tauira kupu		
<ul style="list-style-type: none"> <li>ture tātai</li> <li>koki taurite</li> <li>mati ā-ira</li> <li>pūtakerua</li> </ul>	<ul style="list-style-type: none"> <li>rārangi pūtahi</li> <li>koki tauwhiti</li> <li>tāitaitai</li> </ul>	<ul style="list-style-type: none"> <li>koki tauaro</li> <li>tāroa</li> <li>pūrua</li> </ul>

## He Tauira Rapanga

### Te Ine me te Hanga 5a

#### Rapanga 7

He mahere tēnei o tētahi kokonga huarahi. E whakaarohia ana kia hangaia he huarahi torotika mai i te A ki te E (te rārangi wheno).

- E hia manomita te roa o taua huarahi?
- E hia te rahi o te koki e tohua ana ki te e?

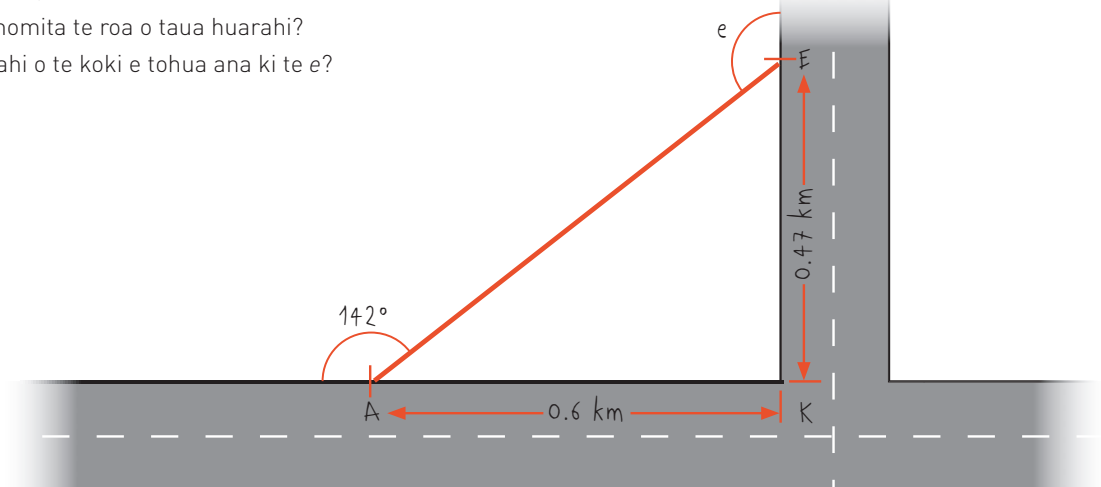

- Kia tika te whakamahi i te ture a Pythagoras hei tātai i te tāroa o te tapatoru, me te whakamārama i ngā mahi:

Ko tā te ture a Pythagoras e mea ana, ko te tapeke o ngā pūrua o ngā tapa poto, he rite ki te pūrua o te tapa roa o tētahi tapatoru hāngai. Arā:

$$a^2 + e^2 = j^2$$

$$0.6^2 + 0.47^2 = AE^2$$

$$0.76 = AE \text{ (mā te tāitaitai, kia 2 ngā mati ā-ira)}$$

- Kia tika hoki te whiriwhiri i te koki e, me tētahi whakamārama pēnei:

E 38° te koki KAE nā te mea ko te 180 te tapeke o ngā koki o tētahi rārangi torotika (142 + 38 = 180).

Nō reira, e 52° te koki KEA, nā te mea 180 te tapeke o ngā koki o tētahi tapatoru (38 + 90 + 52 = 180).

Nō reira, 128° te koki e, nā te mea 180 te tapeke o ngā koki i te rārangi torotika (52 + 128 = 180).

## Te Ine me te Hanga 5a

### Rapanga 8

Hoahoatia tētahi māra rewa mō tō kura. Kia whai āhua rerekē te hanga o tō māra, arā pea, he wāhanga tapatoru, he wāhanga porowhita, he wāhanga tapawhā hāngai rānei.

1. Tuhia te hoahoa ki te pepa, me te whakaatu anō i ngā inenga.
2. Tātaihia te rōrahi o te oneone hei whakakī i te māra rewa. Whakamāramahia ngā tātaianga katoa.

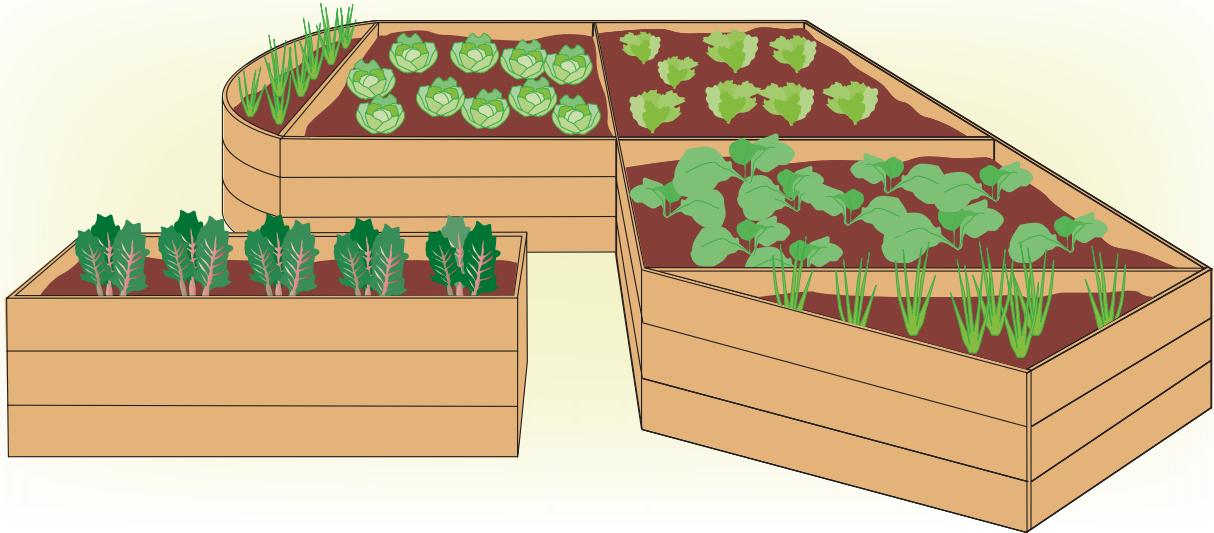

Kia tika te hoahoa i te māra me te whakaatu i ngā inenga tapa.

Ka wāwāhia ngā āhua o te māra, ā, ka whakamahia ngā ture e hāngai ana ki ia āhua hei tātai i te rōrahi.

## Te Wāhi, te Ahunga, me te Panoni

Ngā Whāinga		
Ka whakaoti rapanga te ākonga, ka whakamārama otinga, e whai wāhi mai ana:	He tauira ēnei o ngā āhuatanga me mātua mōhio te ākonga e tutuki ai tana whakaoti rapanga:	
<ul style="list-style-type: none"> <li>te hangarite<sup>13</sup> o ngā koki o ngā rārangi pūtahi<sup>14</sup>, ngā rārangi whakarara<sup>15</sup>, ngā taparau, me ngā matarau</li> <li>te whakaatu me te whakamārama panoni ki te papa kauwhata.</li> </ul>	<ul style="list-style-type: none"> <li>te whakamahi pere<sup>16</sup> hei whakaatu nekehanga</li> <li>te whakamahi mahere me ōna āhuatanga katoa (pērā i te tukutuku<sup>17</sup> me te āwhata<sup>18</sup>) hei whakaahua huarahi.</li> </ul>	<sup>13</sup> symmetry <sup>14</sup> intersecting lines <sup>15</sup> parallel lines <sup>16</sup> vector <sup>17</sup> grid <sup>18</sup> scale

## Te Reo Matatini o te Pāngarau

Hei tauira kupu		
<ul style="list-style-type: none"> <li>pere</li> <li>mātātuhi</li> <li>ahopou</li> </ul>	<ul style="list-style-type: none"> <li>rārangi whakarara</li> <li>mātāoroko</li> <li>āwhata</li> </ul>	<ul style="list-style-type: none"> <li>rārangi pūtahi</li> <li>ahopae</li> </ul>
Hei tauira whakaahuhanga		
<ul style="list-style-type: none"> <li>he mahere āwhata</li> </ul>	<ul style="list-style-type: none"> <li>te pere</li> </ul>	<ul style="list-style-type: none"> <li>te papa kauwhata</li> </ul>

## He Tauira Rapanga

Te Wāhi, te Ahunga, me te Panoni 5a

### Rapanga 9

**Rauemi:** He pepa tukutuku.

Ka mahi takirua ngā ākonga. Mā ia ākonga e tuhi tētahi āhua tapa torotika ki te papa kauwhata, me ngā panoni e rua o taua āhua. Kātahi ka whakamōhio atu ki te hoa i ngā pūwāhi o ngā akitu o te āhua me tōna mātātuhi i muri i ngā panoni e rua. Ko tā te hoa, he āta whiriwhiri i ngā panoni e rua. Hei tauira:

Koia nei te āhua, tōna mātātuhi me ngā panoni e rua (ka whakaatanga i te rārangi  $y = x$ , kātahi ka nekea whakararo kia rua).

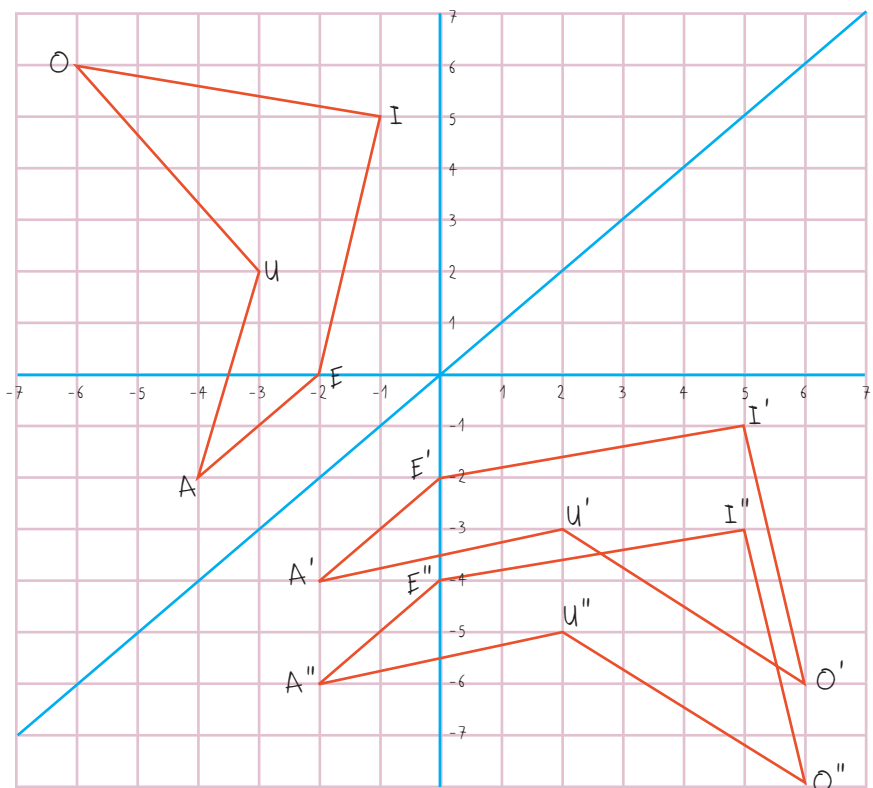

Kia tika te whakaatu pūwāhi (takirua raupapa). Kia tika hoki te whiriwhiri me te whakamārama i ngā panoni.

Te Wāhi, te Ahunga, me te Panoni 5a

## Rapanga 10

**Rauemi:** He pukapuka mahere, he rūri, he ine-koki.

Ka mahi takirua ngā ākonga. Mā ia ākonga e whiriwhiri ētahi tāone e rua i tētahi mahere. Kātahi ka whakamōhio atu ki te hoa i te wāhi noho o tētahi o ngā tāone (mā te whakamahi i tōna ahopae me tōna ahopou) me te ahunga, te tawhiti hoki o te tāone tuarua. Ko tā te hoa, he kimi i te tāone tuatahi, me te whiriwhiri anō i te tāone tuarua.

Kia tika te whakamahi i te ahopae me te ahopou, te āwhata o te mahere, ngā ahunga o te kāpehu me te ine-koki hei whakamārama, hei whiriwhiri i ngā tāone. Hei taurira:

- I rere atu au i te tāone e pātata ana ki te haukotinga o te ahopae  $17.4^\circ$  ki te tonga me te ahopou  $150.3^\circ$  ki te uru. E  $252^\circ$  te ahunga o taku wakarererangi, 1 000 km te tawhiti. Ka tau atu ki hea?

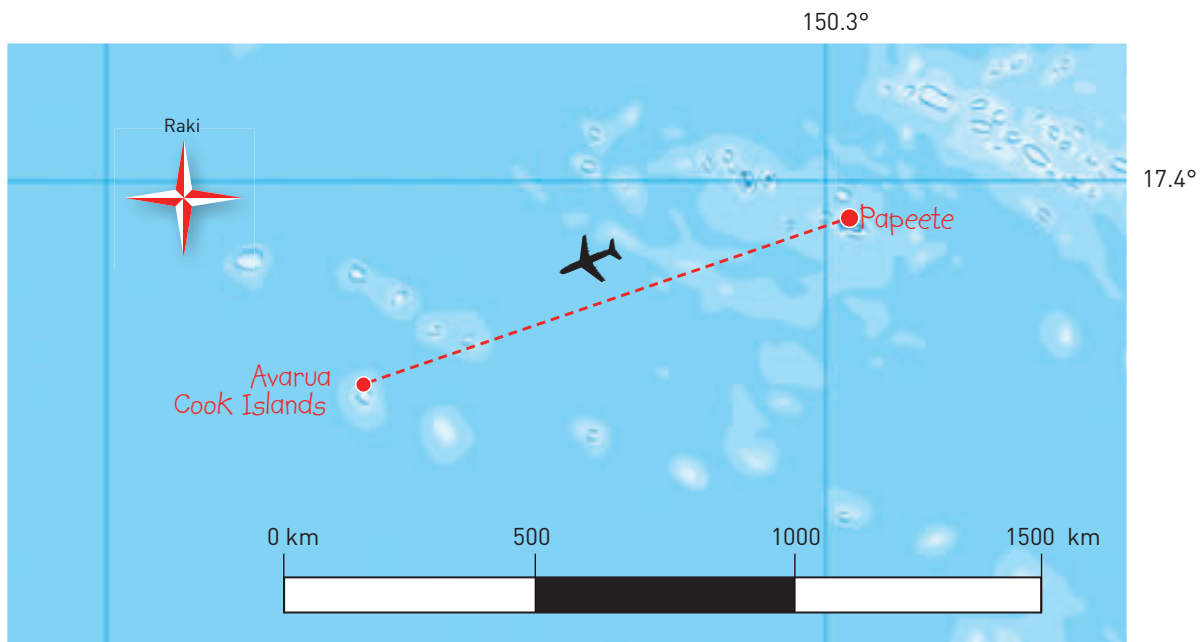



## Te Tauanga

Ngā Whāinga		
Ka whakaoti rapanga te ākonga, ka whakamārama otinga, e whai wāhi mai ana:	He tauira ēnei o ngā āhuatanga me mātua mōhio te ākonga e tutuki ai tana whakaoti rapanga:	
<ul style="list-style-type: none"> <li>te whakatakoto pātai, <b>tāpaetanga kōrero</b><sup>19</sup> rānei, te whakahaere tūhuratanga tauanga, me te whakaputa pūrongo</li> <li>te <b>arotake</b><sup>23</sup> i ngā kōrero ka puta i tētahi tūhuratanga tauanga</li> <li>te whakaputa kōrero mō te pānga o tētahi <b>taurangi</b><sup>26</sup> ki tētahi.</li> </ul>	<ul style="list-style-type: none"> <li>te whakaatu raraunga ki te <b>kauwhata kauamo</b><sup>20</sup> me te <b>kauwhata marara</b><sup>21</sup></li> <li>te whaitake me te whaihua o ngā momo <b>whakaari raraunga</b><sup>22</sup></li> <li>ngā <b>tikanga matatika</b><sup>24</sup> e hāngai ana (pērā i te tikanga kia kua e <b>haukumea</b><sup>25</sup> te āhua o ngā pātai).</li> </ul>	<p><sup>19</sup>assertion</p> <p><sup>20</sup>box and whisker graph</p> <p><sup>21</sup>scatter plot</p> <p><sup>22</sup>data display</p> <p><sup>23</sup>evaluate</p> <p><sup>24</sup>ethical conventions</p> <p><sup>25</sup>be biased</p> <p><sup>26</sup>variable</p>

## Te Reo Matatini o te Pāngarau

Hei tauira kupu		
<ul style="list-style-type: none"> <li>tāpaetanga kōrero</li> <li>haukume</li> <li>pānga</li> </ul>	<ul style="list-style-type: none"> <li>kauwhata kauamo</li> <li>taurangi</li> </ul>	<ul style="list-style-type: none"> <li>kauwhata marara</li> <li>pātengi raraunga</li> </ul>
Hei tauira whakaahuahanga		
<ul style="list-style-type: none"> <li>he kauwhata kauamo</li> </ul>	<ul style="list-style-type: none"> <li>he kauwhata marara</li> </ul>	

## He Tauira Rapanga

### Te Tauanga 5a

### Rapanga 11

**Rauemi:** He rorohiko me te whai wāhi atu ki te Ipurangi.

Tikina atu he raraunga i te pae ipurangi [www.censusatschool.org.nz](http://www.censusatschool.org.nz), ka tūhura ai i te āhua o te pānga kei waenganui i te pakeke o te tamaiti me tōna mārō (te tawhiti mai i tētahi pito ki tētahi ina whātoro atu ngā ringaringa ki ngā taha). Whakatairitea te hunga kōtiro me te hunga tamatāne, ka whakaputa kōrero ai.

Tonoa mā te ākonga e whakatakoto tētahi pātai, tētahi tāpaetanga kōrero rānei hei tūhura māna i ngā raraunga o "Tatauranga ki te Kura" [www.censusatschool.org.nz](http://www.censusatschool.org.nz):

- ka tūhuratia te pānga o tētahi taurangi ki tētahi
- ka whakaputaina he pūrongo me ngā momo whakaari raraunga e whaitake ana.

**Kia mōhio te ākonga ki:**

- te whakatakoto pātai, tāpaetanga kōrero e hāngai ana ki te huinga raraunga
- te tūhura i ngā raraunga
- te whakaatu raraunga ki ngā momo whakaari e hāngai ana
- te whakaputa kōrero mō ngā whakakitenga matua me te pānga o tētahi taurangi ki tētahi.

## Te Tūponotanga

Ngā Whāinga		
Ka whakaoti rapanga te ākonga, ka whakamārama otinga, e whai wāhi mai ana:	He tauira ēnei o ngā āhuratanga me mātua mōhio te ākonga e tutuki ai tana whakaoti rapanga:	
<ul style="list-style-type: none"> <li>tētahi pūāhua tūponotanga papa-maha<sup>27</sup>.</li> </ul>	<ul style="list-style-type: none"> <li>te tātai tūponotanga o tētahi pāpono raupapa<sup>28</sup>.</li> </ul>	<sup>27</sup> multi-level <sup>28</sup> combined event

## Te Reo Matatini o te Pāngarau

Hei tauira kupu		
<ul style="list-style-type: none"> <li>pāpono raupapa</li> </ul>	<ul style="list-style-type: none"> <li>hoahoa rākau</li> </ul>	<ul style="list-style-type: none"> <li>matapōkere</li> </ul>
Hei tauira whakaahuahanga		
<ul style="list-style-type: none"> <li>he hoahoa rākau</li> </ul>		

## He Tauira Rapanga

### Te Tūponotanga 5a

### Rapanga 12

Nā Wiremu i hanga tētahi pūrere takahurihuri, nā Māia hoki tētahi i hanga. E tohe ana a Wiremu he nui ake te tūponotanga ka tau tana pūrere ki te rohe whero i te tūponotanga ka tau te pūrere a Māia ki te rohe whero.

- He pēhea nei ō whakaaro ki te tohenga nei a Wiremu? Whakamāramatia mai he aha i pērā ai ō whakaaro.
- Whakamātauria tēnei tohenga a Wiremu. Tuhia he pūrongo mō tō whakamātau.

te pūrere takahurihuri a Wiremu

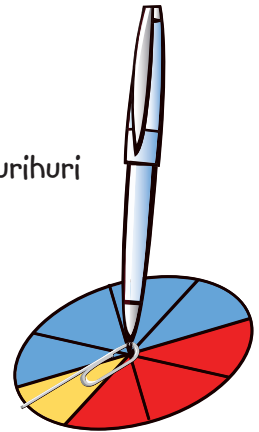

- Kia whitake te matapae me te whakamārama. Hei tauira:
  - He ōrite te tūponotanga ka tau ki te rohe whero i ia pūrere takahurihuri, nā te mea he  $\frac{3}{8}$  te hautanga whero o ia porowhita.
  - He nui ake pea te tūponotanga ka tau ki te rohe whero i te pūrere a Māia, nā te noho wehe o ngā hauwaru whero e toru.
  - He nui ake pea te tūponotanga ka tau ki te rohe whero i te pūrere a Wiremu, nā te piri tahi o ngā hauwaru whero e toru.

te pūrere takahurihuri a Māia

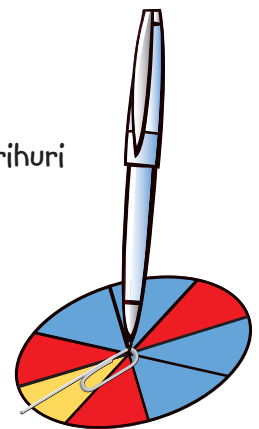

- Kia tika te whakarite me te whakatutuki i te whakamātau tūponotanga.

Arā pea:

- Kia maha ngā takahurihanga o ia pūrere (ki te takiwā pea o te 50 te itinga iho), me te whakamārama mēnā he iti noa iho ngā takahurihanga, he nui kē atu te tūponotanga ka tītaha ngā putanga.
- Ka whakaaturia ngā putanga ki tētahi tūtohi, tētahi kauwhata rānei.
- Ka puta he whakataunga i te tohenga a Wiremu i runga i ngā putanga o te whakamātau.

## Te Takenga mai o Ētahi o ngā Ngohe

I pūtake mai ētahi o ngā ngohe o tēnei pukapuka i rauemi kē.

Koia nei te rārangi o aua ngohe me ngā rauemi e hāngai ana:

- 1e.8 He Pūtahi Pāngarau, *Te Roa, Te Horahanga, Me Te Rōrahi: Mā Te Pouako*, whārangi 16–17. I whakaputaina e Te Pou Taki Kōrero i te tau 2006.
- 1e.9 He Pūtahi Pāngarau, *Te Roa, Te Horahanga, Me Te Rōrahi: Mā Te Pouako*, whārangi 24. I whakaputaina e Te Pou Taki Kōrero i te tau 2006.
- 2e.9 NEMP 2005.
- 2e.10 NEMP 2005.
- 2e.11 NEMP 2005.
- 3e.8 NEMP 2005.
- 3e.9 NEMP 2005.
- 3e.12 Te pae tukutuku nzmaths, te kōwae ako *Papa Raraunga 2* ([www.nzmaths.co.nz/resource/he-papa-raraunga-2](http://www.nzmaths.co.nz/resource/he-papa-raraunga-2))
- 4a.7 He Pūtahi Pāngarau, *Te Whārite: Mā Te Pouako*, whārangi 62. I whakaputaina e Te Pou Taki Kōrero i te tau 2008.
- 4a.13 He Pūtahi Pāngarau, *He Āhua Ahu-3 Me Te Ahunga: Mā Te Pouako*, whārangi 42. I whakaputaina e Te Pou Taki Kōrero i te tau 2005.
- 4e.5 Te pae tukutuku nzmaths, Āpitianga Pātai Rautaki, Kaupae 8, Te Poutama Tau ([www.nzmaths.co.nz/sites/default/files/Numeracy/GloSSL8.pdf](http://www.nzmaths.co.nz/sites/default/files/Numeracy/GloSSL8.pdf))
- 4e.6 NEMP 2005.
- 4e.8 He Pūtahi Pāngarau, *Te Wā: Mā Te Pouako*, whārangi 34. I whakaputaina e Te Pou Taki Kōrero i te tau 2006.
- 4e.9 NEMP 2005.
- 4e.13 Te pae tukutuku nzmaths, Ripanga Kapa Haka ([www.nzmaths.co.nz/resource/ripanga-kapa-haka](http://www.nzmaths.co.nz/resource/ripanga-kapa-haka))
- 5a.1 Te Poutama Tau, *Pukapuka Tuawhitu: Te Hautau, te Tau ā-Ira, te Ōrau* (2009), whārangi 116
- 5a.2 Te Poutama Tau, *Pukapuka Tuawhitu: Te Hautau, te Tau ā-Ira, te Ōrau* (2009), whārangi 151
- 5a.11 Te pae tukutuku nzmaths, Whārangi Mahi 4 o te kōwae ako Hoahoa Tūponotanga ([www.nzmaths.co.nz/resource/hoahoa-t-ponotanga](http://www.nzmaths.co.nz/resource/hoahoa-t-ponotanga))

# HE KUPU TAKA

ahopae	latitude
ahopou	longitude
āhua ahu-2	2-dimensional shape
āhua ahu-3	3-dimensional shape
āhuahanga	geometry
āhuatanga hanga	geometric property
āhuatanga herekore	associative property
āhuatanga kōaro	commutative property
āhuatanga kōhure	distinctive feature
āhuatanga tohatoha	distributive property
ahunga	direction
akitu	vertex
anga pirepire	bead frame, Slavonic abacus
anga tekau	tens frame
āputa	gap
arohaehae	critique
arorau	logical
arotake	review, evaluate
auaha	creative
āwhata	scale
hanganga	construction
hātepe	algorithm
haukotinga	intercept
haukume	bias
hautanga ā-ira	decimal fraction
hautau	fraction
hautau waetahi	unit fraction
hoahoa	diagram
hoahoa āwhata	scale diagram
hoahoa inerite	isometric diagram
hoahoa pere	arrow diagram
hoahoa rākau	tree diagram
horahanga	area
horopaki	context
huānga	element, member

huatango	difference (between two numbers)
hurihanga hangarite	rotational symmetry
huripoki	flip
ia	trend
inaki	overlap
kapa	row
kāpehu	compass (for direction)
kauwhata ira	dot graph
kauwhata porowhita	pie graph
kauwhata pou	bar graph
kauwhata pou hiato	composite bar graph
kauwhata pou whakaapaapa	stacked bar graph
kauwhata pouhere	histogram
kauwhata rārangi	line graph
kauwhata rautō	stem and leaf graph
kauwhata rautō hiato	composite stem and leaf graph
kauwhata whakaahua	picture graph
kītanga	capacity
kōaro	anti-clockwise, inverse
koki hāngai	right angle
koki hāpūpū	obtuse angle
koki rāwaho	reflex angle
koki roto	interior angle
koki tāhapa	acute angle
koki tauaro	opposite angle
koki taurite	corresponding angle
koki tauwhiti	alternate angle
koki whakahāngai	complementary angle
mahere	map, plan
manei	fluctuate
mata	face
mataono rite	cube
mataono tau	dice
mātāoroko	object (before transformation)

matapae	predict
matapōkere	random
matarau	polyhedron
mātātuhi	image (after transformation)
mātauranga tau	number knowledge
mati ā-ira	decimal place
meka matua	basic fact
meka tāpiritanga	addition fact
mōwaho	outlier
neke	translate (slide)
ōrau	percent
otinga	result, answer
ōwehenga	ratio
paenga	perimeter
paetaha	sideline
paheko kōaro	inverse operation
paheko tau	number operation
pākete	1. bucket 2. packet
pānga	relationship
panoni	transformation
papa tīrau	geoboard
papa-hautekau	tenths board
papa-maha	multi-level
paparanga	layer
paparau	hundreds board
pāpātanga	rate
pāpono	probability event
pāpono aukati	mutually exclusive event
pāpono raupapa	combined event
pāpono wehe kē	independent event
pāpono whakawhirinaki	dependent event
pātengi raraunga	database
pene whītau	felt pen
penerākau karakara	coloured pencil
pere	vector

poraka āhuatanga ake	attribute blocks
poro	1. prism 2. block (poraka)
porotiti	counter
porowhita hautau	fraction circle
pou	column
pū whakarahi	centre of enlargement
pūāhua whaitake	practical situation
pūmau	invariant
pūrere takahurihuri	spinner (revolving device)
pūrua	power of two
pūtahi	intersect
pūtakerua	square root
putanga	outcome
putanga matapae	theoretical outcome
putanga whakamātau	experimental outcome
putu	degree (unit for angle and temperature)
rākau Ātaarangi	Cuisenaire rod
rangirua	uncertain
rāpoi	cluster
rārangi hangarite	line of symmetry
rārangi tau	number line
rārangi tau matarua	double number line
rārangi tau wātea	blank number line
raraunga	data
raraunga houanga	time-series data
raraunga motukore	continuous data
raraunga motumotu	discrete data
raraunga whakarōpū	category data
raraunga whakarōpū matatini	multivariate category data
raumata	net (of a 3-dimensional shape)
rautaki tau	number strategy
rearua	double, two times
ripanga	spreadsheet
ripanga rorohiko	computer spreadsheet



rōnaki	slope, gradient
rōrahi	volume
taitapa	frame
takirua raupapa	ordered pair
tānga ngahuru	standard form
tapa	edge
tāpaetanga kōrero	assertion
taparau	polygon
tapatoru hāngai	right angled triangle
tapatoru hikuwaru	scalene triangle
tapatoru rite	equilateral triangle
tapatoru waerite	isocetes triangle
tapawhā whakarara	parallelogram
tapeke	total
tāpiritanga tāruarua	repeated addition
tāporowhita	compass (for drawing a circle)
tāroa	hypotenuse
tātai	calculate
tātaimai	calculator
tatau ake	count on
tatau mawhiti-rima	skip counting in fives
tatau māwhitiwhiti	skip counting
tatau pānga-tahi	one-to-one counting
tau aho	light year
tau ā-ira	decimal number
tau māmā	tidy number/easy number
tau tānui	mode
tau tōpū	integer
tau tōraro	negative number
tau tōrunga	positive number
tau waenga	median
tauanga	statistics
tauahono	addend (number being added)
tauirā	pattern
tauirā raupapa	sequential pattern

tauirā tāruarua	repetitive pattern
taunga	position, coordinate
tauoti	whole number
taupori	population
taupū	power, exponent
taurahi	scale factor
taurangi	1. algebra 2. variable
tauraro	denominator
taurea	multiple
taurunga	numerator
tautohu	identify
tauwehe	factor
Te Mahere Tau	The Number Framework
te reo matatini o te pāngarau	pāngarau literacy
Te Uiu Aromatawai o Te Poutama Tau	Te Poutama Tau Diagnostic Interview
tikanga matatika	ethical conventions
tikanga paremata	compensation method
tīpako	sample, selection
tirohanga	view
toharite	average, mean
tohenga	argument
tōkeke	fair
tuaka pae	horizontal axis (x-axis)
tuaka pou	vertical axis (y-axis)
tuari	distribution
tūhurātanga tauanga	statistical investigation
tukutuku	grid
tūponotanga	probability, chance
tūtohi	chart, table (of data)
tūtohi tatau	tally chart
uara tū	place value
waeine aro kē	non-standard unit of measurement
waeine aro whānui	standard unit of measurement
wātaka	timetable



wāwāhi tau	1. partition (a number) 2. part-whole
wēanga	measure of central tendency
whakaahua ā-hinengaro	mental image
whakaahuhanga	representation
whakaari raraunga	data display
whakaata	reflect
whakaawhiwhi	round (a number)
whakamāori	interpret
whakaoti rapanga	problem solving
whakarara	parallel
whakarara rite	rhombus
whakatairite mata ki mata	direct comparison
whakatau tata	estimate
whārite	equation
whenu	strand







Te Kāwanatanga o Aotearoa

ISBN 978-0-7903-3643-5



9 780790 336435